

ASME Class 900 / 1500 / 1700 / 2500 / 2700 (4500)

API Class 6.000 PSI (10.000 PSI)

Standards

Design: ASME B16.34 - BS-EN 15761 - EN 12516

Buttwelding Ends: ASME B16.25 - DIN-EN 9692-1 - EN 12627

Socket Welding Ends: ASME B16.11 - EN 12760

Other End Connections: API OR NPT Female Threads / Clamp Connectors / Flanged RTJ or RF

End-to-end Dimensions: Manufacturer's Standard (Flanged Valves Acc. The Relevant Standard)

Pressure Testing: ASME B16.34 - API 598 - DIN 3230 - EN 12266

Materials

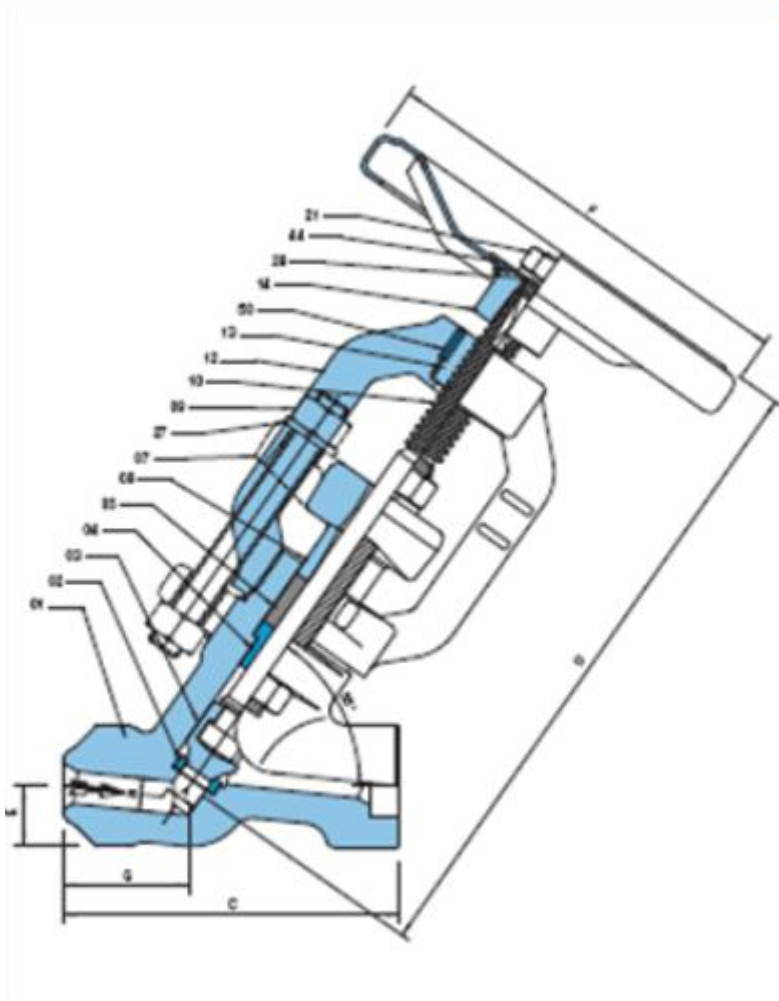

Body Various (see Below)

02 Seat: Stellite

03 Disc: Stellite

04 Loose Backseat: AISI 304

05 Stem Packing: Graphite

07 Gland Flange: Carbon Steel

08 Gland: AISI 304

09 Gland Bolt/Nut: ASTM-a193-b7/
ASTM-a194-2h

10 Stem: 17 Cr (see Below)

12 Yoke: Carbon Steel

13 Yoke Sleeve: Aluminium-bronze

14 Handwheel: Carbon Steel

21 Nut: Steel Zinc Plated

27 Spring washer: Steel Zinc Plated

28 Spring washer: Steel Zinc Plated

44 Nameplate: Aluminium

50 Pin: Hardened Steel

Features

Design: Construction Integral Bonnet (bonnetless) And Loose Backseat (fixed Backseat Optional)

Seat Ring: High Temperature Vacuum Brazed In Seat Ring With Thickness > 5 Mm (1/5")

Options: Also In Sizes Exceeding 2" (fig 02.2) And As Screw-down Non-return Valve

Operation: Optional Non-rotating One-piece Stem/disc For Electric Or Pneumatic Actuator (fig 02.2)

Accessories: Limit Switches - Locking Device - Position Indicator - Live Loaded Gland (others On Request)

Materials: Body SA105n - SA182-f22 - SA182-f91 - SA182-F316(L) (Others On Request)

Trim 17cr/Stellite - F316/Stellite (Others On Request)

Stem Packing Graphite With Integral Or Stainless Steel Reinforced Anti Extrusion Rings

Main Dimensions In MM (Inch)

NOM. SIZE	A	B	C	D	E	F	G	Cv	WEIGHT KG
10 (3/8")	11 (0.43)	7 (0.28)	115 (4.53)	236 (9.29)	21 (0.83)	150 (5.91)	43.3 (1.70)	1.5	3.4 (7.5 LB)
15 (1/2")	11 (0.43)	11 (0.43)	115 (4.53)	236 (9.29)	21 (0.83)	150 (5.91)	43.3 (1.70)	2.7	3.3 (7.3 LB)
20 (3/4")	18 (0.71)	16 (0.63)	140 (5.51)	291 (11.46)	29 (1.14)	200 (7.87)	51.5 (2.02)	8.0	5.9 (13.0 LB)
25 (1")	18 (0.71)	20 (0.79)	140 (5.51)	291 (11.46)	29 (1.14)	200 (7.87)	51.5 (2.02)	8.7	5.7 (12.6 LB)
32 (1-1/4")	36 (1.42)	30 (1.18)	245 (9.65)	469 (18.46)	50 (1.97)	350 (13.78)	85.0 (3.35)	34.4	28.9 (68.7 LB)
40 (1-1/2")	36 (1.42)	30 (1.18)	245 (9.65)	469 (18.46)	50 (1.97)	350 (13.78)	85.0 (3.35)	34.4	28.9 (68.7 LB)
50 (2")	36 (1.42)	40 (1.57)	245 (9.65)	469 (18.46)	50 (1.97)	350 (13.78)	85.0 (3.35)	44.2	27.6 (60.8 LB)

Phone: 0086 0577 5768 9696, Fax: 0086 0577 5768 7959

E-mail: sales@uvalves.com

Website: <http://www.valvesforged.com/>