

Performance Specification		PN16	
Nominal Pressure	2.4		
Shell	1.76		
Seal	-		
Upper Seal	-		
MPa	0.6		
Testing Pressure	-		
Air	-		
Suitable Temp	-29~150		
℃	-		
Application: Water, Gas, Oils			

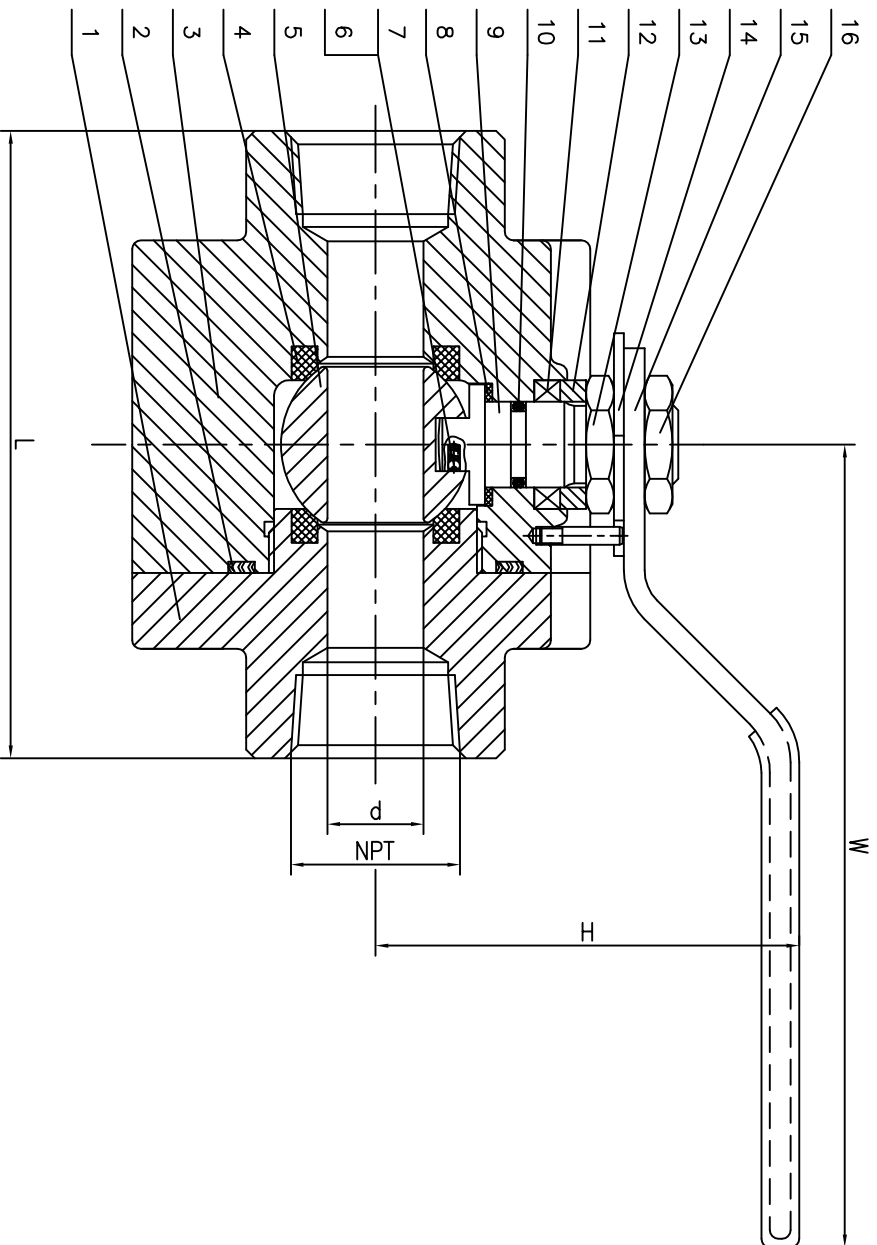

ITEM NO	Nominal Diameter	Main Dimensions (mm)					
		DN	d	NPT	L	H	W
2	2"	50	49	2"	97	126	290

16	Nut	ASTM A194 8M	
15	Lever	C.S.+PVC	
14	Locating Plate	C.S.	
13	Nut	ASTM A194 8M	
12	Gland	B148 C95800	
11	Packing	Graphite	
10	"O"-Ring	Viton	
9	Stem	B148 C95800	
8	Gasket	PTFE	
7	Small Ball	SS316	
6	Small Spring	SS316	
5	Ball	B148 C95800	
4	Seat Ring	PTFE	
3	Body	B148 C95800	
2	Gasket	PTFE	
1	Bonnet	B148 C95800	
No	Part Name	Material	Remarks

BALL VALVE PN16

Design And Manufacturer	API 608
Face To Face Dimension	-
Threaded End Dimension	ASME B1.20.1
Pressure Test	API 598

XIAMEN LANDEE INDUSTRIES CO.,LTD