

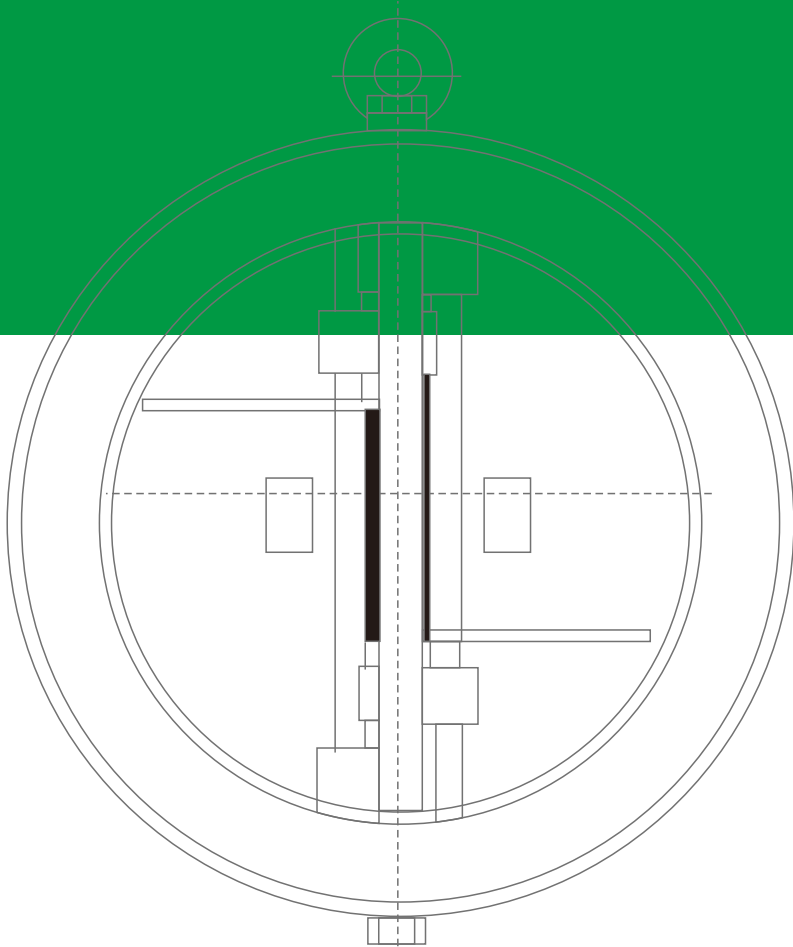

API6D Dual plate check valve



WAFER TYPE LUG
TYPE FLANGED TYPE

JSC VALVE 

JSC Union is committed to enhancing our customers' working site safety, system stability, and convenient operations through our valve product offerings. Our diverse and innovative valves will have more safety design, longer working life and more reliable operation.

Located in the city with a more than forty years' history to make industrial valve, RUV has carried on the mature valve manufacturing tradition of Zigong city. By our advanced seat design and special workmanship, we are making high quality ball valve, through conduit gate valve and dual plate check valve, range from complete size and pressure for petroleum, chemical, and energy industrial use. To be a professional API6D valve company, we are making for reliability.



Dual Plate Check Valve

Applications.....	page 1
Feature.....	page 3
Advantages.....	page 4
Models.....	page 5
Materials.....	page 6
Dimensions.....	page 7
Flange type design.....	page 10
Lug type design.....	page 11
Stud selection.....	page 12
Flow rate ranges.....	page 14
Fig.NO.....	page 16

A wide variety of body designs, materials, and trim make RUV Dual Plate Check Valves exceptionally versatile and suitable for a multitude of liquid and gas fluid applications.

● Petroleum Refining

- Hydrogen Gasoline
- Cracking Visbreakers
- Steam Naptha
- Crude Oil Sulfur



● Oil and Gas Production

- Centrifugal Compressor Discharge
- Fire Water Lines
- Oil/Steam Separation
- Steam and Co2 Injection
- Gas/Oil Gathering Systems
- Flowlines
- Wellheads

● Petrochemicals

- Ethylene
- Propylene
- Steam
- Reboilers
- Gases

● Power Generation

- Steam
- Condensate
- Boiler Feed Pumps
- Cooling Towers
- Service Water Recirculators
- River Water Recirculators
- River Water Intake

● Chemicals

- Chlorine
- Phosgene
- Aromatics
- Polymers
- Acids
- Air Separation
- Cautics

● Steel/Primary Metals

- Quench Lines
- De-Scaling
- Continuous Casters
- Steam
- Condensate
- Strippers
- Electro-Galvanizing

● Pulp and Paper

- Bleaching Lines
- Black Liquor
- Green Liquor
- White Water
- Steam
- Chemical Recovery

● Marine

- Oil Tankers
- Tanker Loading Terminals
- Offshore Platforms
- Sub-Sea Manifolds
- Terminal Transfer Lines
- Barge Unloading Lines
- Sipboard Services

● Water and Wastewater

- Distribution Lines
- Pumping Stations
- Sewage Plant Blower Discharge
- Chemical Treatment
- Fire Protection Systems
- HVAC Systems



The JSCy Union dual plate check valve design
Conforms to API594 and API6D. And it is generally stronger, lighter, smaller, more efficient and less expensive than conventional swing check valves. It has about 25% the face to face dimension and 15% to 20% the weight of a swing check valve and making them less expensive than a swing check valve. It is much easier to install between standard gaskets and line flanges.



● DESIGN FEATURES

Easy to install and maintain

Manufactured to API594 and tested to API598

Smooth, spring-assisted closing reduces water hammer

All WCB and 316 SS valves conform to NACE MR-01-75

Rugged Inconel X-750 spring is standard in all steel and stainless steel valves

Innovative 316 SS seat, standard in all WCB metal-seated valves, combined with standard 316 SS plates provides a true all stainless steel seating area

Long-legged springs allow plates to open and close without seat scrubbing

Economical, lightweight, compact design—significantly lighter and less expensive than comparable swing check valves

Light weight, versatile design, 80 to 90% lighter than conventional full-body check valves.

Reduces pipe supports, simplifies piping, easier, less costly installation.

- Reduced thermal and seismic considerations
- No need for additional expensive support
- Optimum space utilization, simplified piping

Discs open 80° to ensure positive closing.

Materials and trims available for all services within temperature range.

Extended leg springs prevent seat wear caused by scrubbing.

Springs are calculated to increase the responsiveness of the disc, thus reducing damaging effects of water hammer.

Resilient or metal-to-metal seat available.

The RUV dual plate check valve design is generally stronger, lighter, smaller, more efficient and less expensive than conventional swing check valves. The design meets API 594 which is approximately 25% the face to face dimension and 15% to 20% the weight, on most popular sizes, making them less expensive than a swing check valve. It is much easier to install between standard gaskets and line flanges. The savings compound during installation due to ease of handling and only one set of flange studs is required. Therefore, it is more cost effective to install, and also to maintain.

The RUV also offers special design features which make it a high performance non-slam check valve. These include a scrub-free opening, and in most sizes a unique independent spring design as well as an independent plate stop hinge pin. Other configurations include lug type and double flange type.

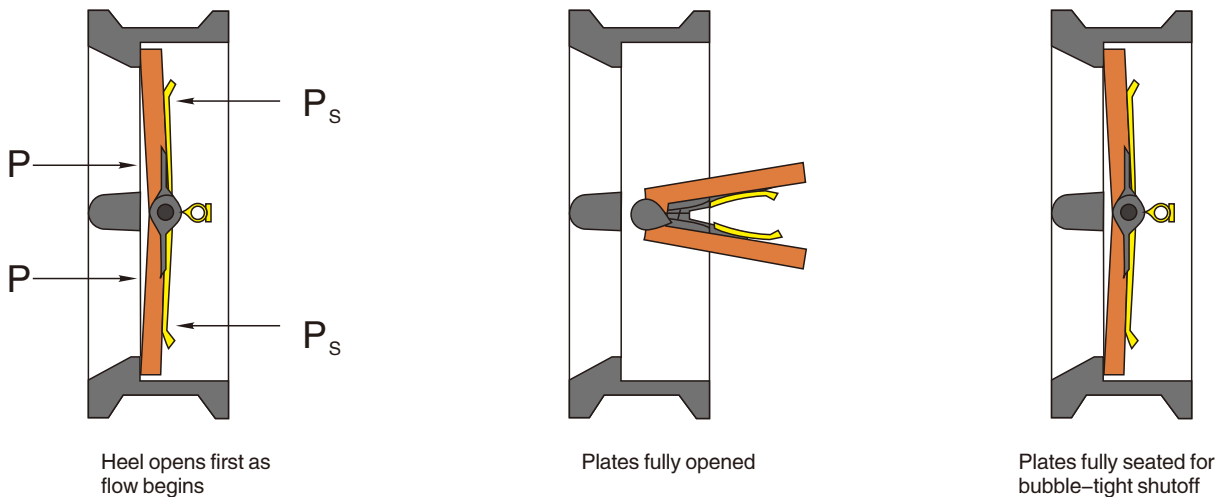

The innovative dual-plate design of the RUV check valve employs one or two spring-loaded plates (disc halves) suspended on a central vertical hinge pin. As flow begins, the plates open in response to a resultant force (P) which acts as the center of the sealed surface area. The contact point of the reacting spring leg's force (P_s) acts beyond the center of the plate area, causing the heel to open first. This prevents rubbing of the seal surface prior to normal plate opening, eliminating wear.

As the velocity of flow decreases, torsion spring action reacts automatically. This moves the plates closer to the body seats, reducing the distance and time of travel for closure. By having the plates closer to the body seats at the time of flow reversal, the valve dynamic response is greatly accelerated. This dramatically reduces the water hammer effect for non-slam performance.

At closing, the point of spring force causes the toe of the plates to close firstly. This prevents dragging of the heels of the plates and maintains seal integrity for much longer periods.

A spring design of RUV dual plate check valve (sizes 6" and larger) allows higher torque to be exerted against each plate with independent closing in response to the process stream. Testing has proved this action provides up to 25% improvement in valve life and 50% reduction in water hammer. Each of the dual plates has its own spring or springs, which provide independent closing action. These independent springs undergo less angular deflection, only 140° as compared to 350° for conventional springs with two legs.

● Independent Plate Suspension Design

The RUV dual plate check valve unique hinge design reduces friction forces by 66%, which improves valve response significantly. Support sleeves are inserted through the outboard hinges so that the upper hinge is independently supported by the lower sleeve during valve operation. This allows both plates to close at the same time for quick response, and excellent dynamic performance.

● Independent Spring Design

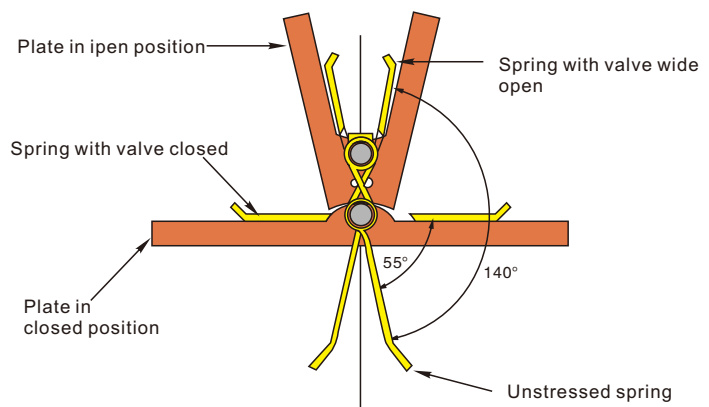

● WAFER TYPE



ASME CLASS					
150	300	600	900	1500	2500
2-36" 50-900mm	2-36" 50-900mm	2-30" 50-750mm	2-24" 50-600mm	2-20" 50-500mm	2-20" 50-500mm

● LUG TYPE



ASME CLASS					
150	300	600	900	1500	2500
2-36" 50-900mm	2-36" 50-900mm	2-30" 50-750mm	2-24" 50-600mm	2-20" 50-500mm	2-20" 50-500mm

● FLANGED TYPE

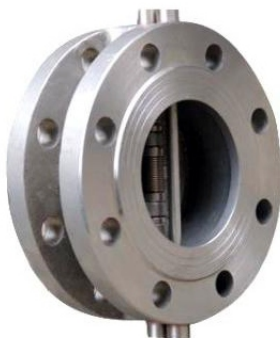

ASME CLASS			
150	300	600	900
2-36" 50-900mm	2-36" 50-900mm	2-30" 50-750mm	2-24" 50-600mm

● INDUSTRY STANDARDS

- ASME B16.1, B16.5, B16.24, B16.34, B16.47, and B31.1
- API 594 AND 598
- MSS-SP-25, MSS-SP-55
- API 6A and 6D (as applicable)
- MSS-SP-61 (standard for the resilient seat, met seated when required)
- NACE MR-01-75 (Latest Edition, when required)

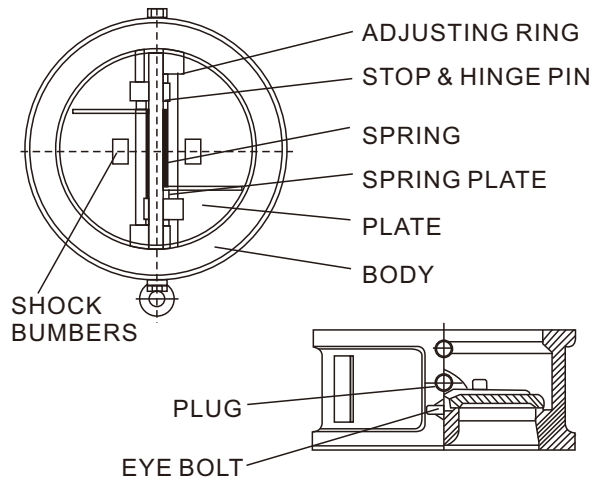

PART NAME	CAST IRON/BRONZE	
BODY	A 126 CAST IRON	A 126 CAST IRON
PLATE	ALUMINUM BRONZE	A 351 CF8M
SPRING	316	316
STOP PIN	316	316
NPT-PLUG	316	316
END BEARING	316	316
BEARING WASHER	316	316
SLEEVE	316	316
SEAT	BUNA-N OR VITON	BUNA-N OR VITON

PART NAME	WCB/316SS	316SS/316SS	CN7M/CN7M
BODY	A216-WCB	A351-WCB	CN7M
PLATE	A351-CF8M	A351-CF8M	CN7M
SPRING	INCONEL X-750	INCONEL X-750	INCONEL X-750
STOP PIN	316	316	ALLOY 20
NPT-PLUG	316	316	ALLOY 20
END BEARING	316	316	ALLOY 20
BEARING WASHER	316	316	ALLOY 20
SLEEVE	316	316	ALLOY 20
SEAT	316 OR VITON	316 OR VITON	A20 OR VITON

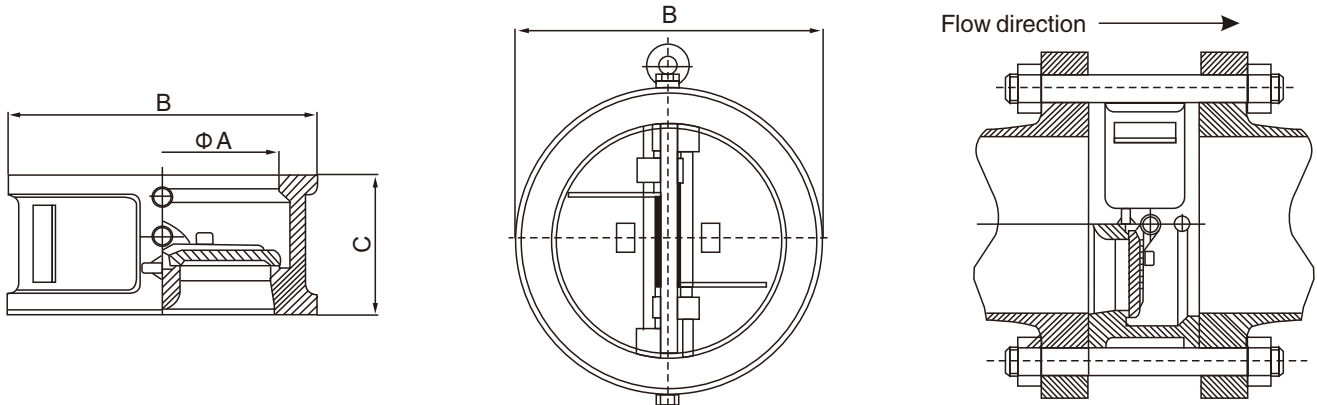

SIZE	CLASS	A		B		C		Weight	
		INCH	MM	INCH	MM	INCH	MM	LBS	KGS
2" 50mm	125	2.375	60.3	4.125	150	2.125	54	4	1.8
	150	2.375	60.3	4.125	150	2.362	60	6	2.7
	300	2.375	60.3	4.375	111	2.362	60	7	3.2
	600	2.375	60.3	4.375	111	2.362	60	7	3.2
	900	2.375	60.3	5.625	143	2.76	70	14	6.4
	1500	2.375	60.3	5.625	143	2.76	70	14	6.4
	2500	2.375	60.3	5.75	146	2.76	70	15	6.8
2-1/2" 65mm	125	2.875	73	4.875	124	2.125	54	6	2.7
	150	2.875	73	4.875	124	2.64	67	10	4.5
	300	2.875	73	5.125	130	2.64	67	11	5
	600	2.875	73	5.125	130	2.64	67	11	5
	900	2.875	73	6.5	165	3.25	83	16	7.3
	1500	2.875	73	6.5	165	3.25	83	16	7.3
	2500	2.875	73	6.625	168	3.25	83	22	10
3" 80mm	125	3.5	88.8	5.375	137	2.25	57	13	3.2
	150	3.5	88.8	5.375	137	2.874	73	7	5.9
	300	3.5	88.8	5.875	149	2.874	73	15	6.8
	600	3.5	88.8	5.875	149	2.874	73	15	6.8
	900	3.5	88.8	6.625	168	3.27	83	24	10.9
	1500	3.5	88.8	6.875	174.6	3.27	83	25	11.3
	2500	3.5	88.8	7.75	197	3.386	86	31	14.1
4" 100mm	125	4.5	114.8	6.875	175	2.5	64	12	5.4
	150	4.5	114.8	6.875	175	2.874	73	17	7.7
	300	4.5	114.8	7.125	181	2.874	73	18	8.2
	600	4.5	114.8	7.625	194	3.11	79	26	11.8
	900	4.5	114.8	8.125	206.4	4.02	102	40	18.1
	1500	4.5	114.8	8.25	209.4	4.02	102	43	19.5
	2500	4.5	114.8	9.25	235	4.13	105	54	24.5
5" 125mm	125	5.5	141	7.75	197	2.76	70	15	6.8
	150	5.62	142.8	7.75	197	3.38	86	27	12.2
	300	5.62	142.8	8.5	216	3.38	86	35	15.9
	600	5.62	142.8	9.5	241	4.125	105	50	22.7

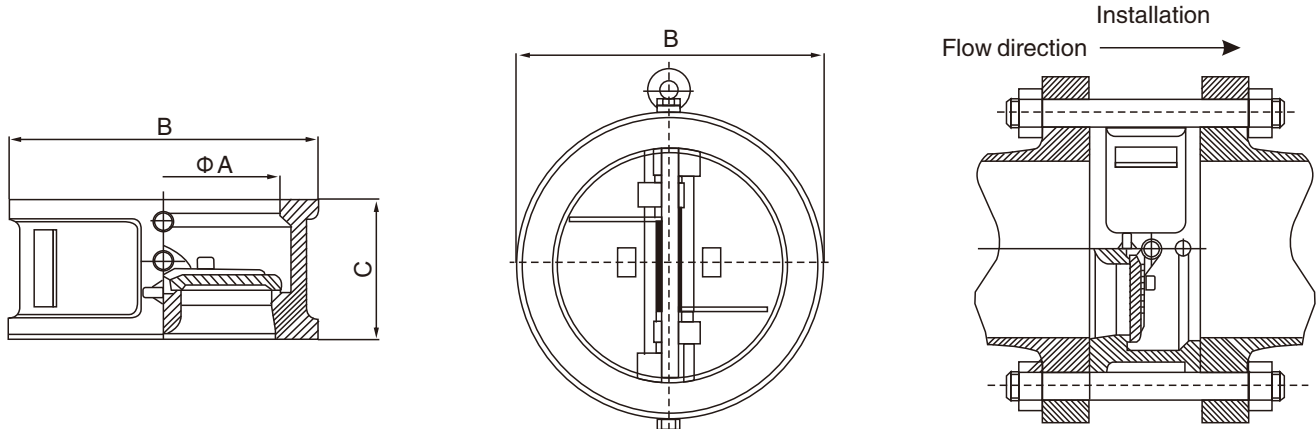

SIZE	CLASS	A		B		C		Weight	
		INCH	MM	INCH	MM	INCH	MM	LBC	KGS
6" 150mm	125	6.625	168	8.75	222	3	76	20	9
	150	6.625	168	8.75	222	3.858	98	35	16
	300	6.625	168	9.875	251	3.858	98	45	20
	600	6.625	168	10.2	267	5.394	137	80	36
	900	6.625	168	11.38	289	6.26	159	115	52
	1500	6.625	168	11.13	282.6	6.26	159	110	50
	2500	6.625	168	12.5	318	6.26	159	190	86
8" 200mm	125	8.625	219.3	11	279	3.75	95	40	18
	150	8.625	219.3	11	279	5	127	70	32
	300	8.625	219.3	12.13	308	5	127	82	37
	600	8.625	219.3	12.64	321	6.5	165	135	61
	900		219.3	14.13	358.8	8.11	206	229	104
	1500	8.625	219.3	13.88	352.4	8.11	206	219	99
	2500	8.625	219.3	15.25	387	8.11	206	285	129
10" 250mm	125	10.75	273.1	13.38	340	8.11	108	65	29
	150	10.75	273.1	13.38	340	4.25	146	106	48
	300	10.75	273.1	14.25	362	5.75	146	125	57
	600	10.75	273.1	15.75	400	8.385	213	238	108
	900	10.75	273.1	17.13	435	9.488	241	388	176
	1500	10.75	273.1	17.13	435	9.76	248	397	180
	2500	10.75	273.1	18.75	476	9.84	250	502	228
12" 300mm	125	12.75	324	16.13	410	5.625	143	110	50
	150	12.75	324	16.13	410	7.12	181	172	78
	300	12.75	324	16.63	422	7.12	181	200	91
	600	12.75	324	18	457	9	229	333	151
	900	12.75	324	19.63	498.5	11.5	292	540	245
	1500	12.75	324	20.5	520.7	12	305	725	329
	2500	12.75	324	21.63	549	12	305	963	437
14" 350mm	125	14	355.6	17.75	451	7.25	184	183	83
	150	14	355.6	17.75	451	7.25	184	200	91
	300	14	355.6	19.13	486	8.74	222	325	147
	600	14	355.6	19.38	492	10.75	273	455	206
	900	14	355.6	20.5	520.7	14	356		
	1500	14	355.6	22.75	577.9	14	356		

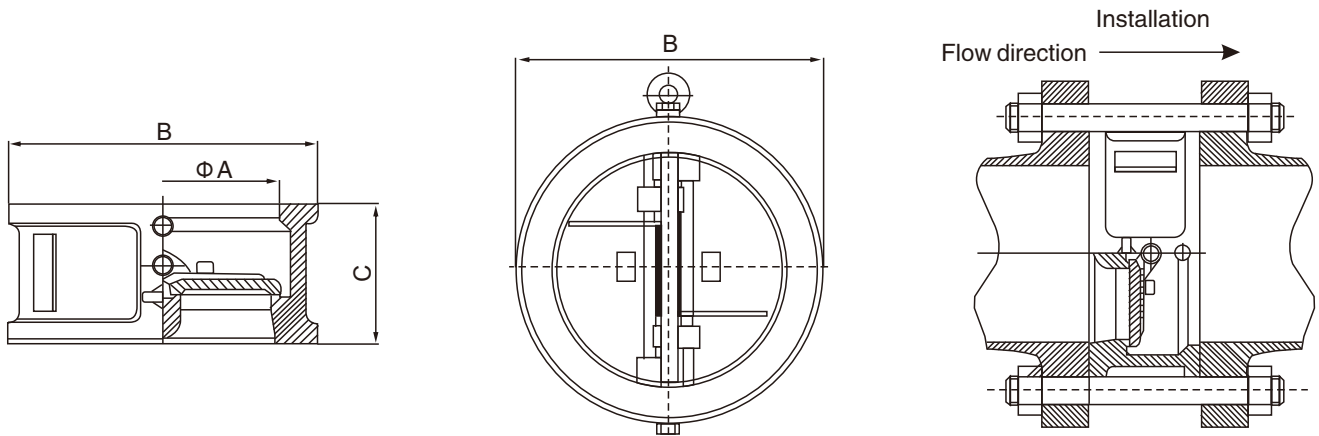

SIZE	CLASS	A		B		C		Weight	
		INCH	MM	INCH	MM	INCH	MM	LBC	KGS
16" 400mm	125	16	406	20.25	514	7.5	191	255	116
	150	16	406	20.25	514	7.5	191	275	125
	300	16	406	21.25	540	9.13	232	415	188
	600	16	406	22.25	565	12	305	640	290
	900	16	406	22.63	574.7	15.12	384		
	1500	16	406	25.25	641	15.12	384		
18" 450mm	125	18	457	21.63	549	8	203	315	143
	150	17	433	21.63	549	8	203	315	143
	300	17	433	23.5	597	10.39	264	555	252
	600	17	433	24.13	613	14.25	362	890	404
	900	17	433	25.13	638.2	17.75	451	1318	598
	1500	18	457	27.75	705	18.42	468	-	
20" 500mm	125	20	508	23.88	606	8.385	213	380	172
	150	20	508	23.88	606	8.62	219	435	197
	300	20	508	25.75	654	11.5	292	725	329
	600	20	508	26.88	683	14.5	368	1120	508
	900	17	433	25.13	638.2	17.75	451	1426	647
24" 600mm	125	24	610	28.25	718	8.75	222	575	261
	150	24	610	28.25	718	8.75	222	620	281
	300	24	610	30.5	778	12.5	318	1100	499
	600	24	610	31.13	791	17.25	438	2040	925
30" 750mm	125	30	762	34.75	883	12	305	1070	485
	150	30	762	34.75	883	13	330	1230	558
	300	30	762	37.5	953	15.69	398	2050	930
36" 900mm	125	36	915	41.25	1048	14.5	368	1962	890
	150	36	915	41.25	1048	15.25	387	2017	915

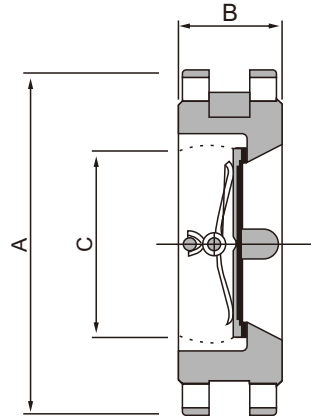
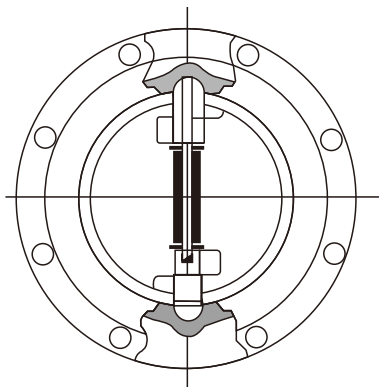

ASME Class 150

Size		A		B		C		Weight	
in	mm	in	mm	in	mm	in	mm	lbs.	kg.
8"	200	13-1/2	343	5	127	7-5/8	194	93	42
10"	250	16	406	5-3/4	146	9-9/16	243	189	86
12"	300	19	483	7-1/8	181	11-3/6	289	218	99
14"	350	21	533	7-1/4	184	12-1/2	318	274	124
16"	400	23-1/2	597	7-1/2	191	15	381	353	160
18"	450	25	635	8	203	16-7/8	428	409	185
20"	500	27-1/2	699	8-5/8	219	18-7/8	480	552	250
24"	600	32	813	8-3/4	222	22-5/8	575	860	389
30"	750	38-3/4	984	13	330	29-1/4	743	1512	687
36"	900	46	1168	15-1/4	387	35	889	2525	1145
42"	1050	53	1346	17	432	41	1041	4163	1888
48"	1200	59-1/2	1511	20-5/8	524	47	1194	5880	2667
54"	1350	66-1/4	1683	21-1/4	539	51-1/2	1308		
60"	1500	73	1854	26	660	56	1422		
66"	1650	80	2032	31	787	62-1/2	1588		
72"	1800	86-1/2	2197	36	914	68	1727		

ASME Class 600

Size		A		B		C		Weight	
in	mm	in	mm	in	mm	in	mm	lbs.	kg.
12"	300	22	559	9	229	11-3/8	289	612	277
14"	350	23-3/4	603	10 3/4	273	12-1/2	318	682	309
16"	400	27	685	12	305	14-3/8	365	951	430
18"	450	29-1/4	743	14 1/4	362	16-1/8	409	1221	553
20"	500	32	813	14 1/4	368	18	457	1606	728
24"	600	37	940	17 1/2	445	21-9/16	548	2451	1111
30"	750	44-1/2	1130	19 7/8	505	28-3/4	730	3825	1735
36"	900	51-3/4	1314	25	635	33-3/4	857	6057	2747
42"	1050	55-1/4	1403	27 5/8	702	39-1/2	1003	9985	4529
48"	1200	62-3/4	1594	31	787	36	914	12600	5715

ASME Class 300

Size		A		B		C		Weight	
in	mm	in	mm	in	mm	in	mm	lbs.	kg.
12"	300	20-1/2	521	7-1/8	181	11-3/8	289	336	152
14"	350	23	584	8-3/4	222	12-1/2	318	431	195
16"	400	25-1/2	648	9-1/8	232	14-3/8	365	619	280
18"	450	28	711	10-3/8	264	16-1/8	409	850	385
20"	500	30-1/2	775	11-1/2	292	17-7/8	454	1078	488
24"	600	36	914	12-1/2	318	22-1/8	562	1516	686
30"	750	43	1092	14-1/2	368	28-3/4	730	3100	1406
36"	900	50	1270	19	483	35	864	4650	2109
42"	1050	50-3/4	1289	22-3/8	568	41	1041	8670	3932
48"	1200	57-3/4	1467	24-3/4	629	47	1193	9950	4513
54"	1350	65-1/4	1657	27-1/4	692	51-1/2	1308		
60"	1500	73	1854	32-1/2	826	56	1422		

ASME Class 900

Size		A		B		C		Weight	
in	mm	in	mm	in	mm	in	mm	lbs.	kg.
12"	300	24	610	11-1/2	292	10-1/8	257	770	349
14"	350	25-1/4	641	14	356	11-1/2	292	1240	561
16"	400	27-3/4	705	15-1/8	384	12-7/8	327	1210	548
18"	450	31	787	17-3/4	451	14-1/2	368	1845	835
20"	500	33-3/4	857	17-3/4	451	18	457	3940	1787
24"	600	41	1041	19-1/2	495	21-1/2	546	4175	1893
30"	750	48-1/2	1222	25	635	26	660	6500	2948
36"	900	57-1/2	1461	28	711	31	787		
42"	1050	61-1/2	1562	31-1/2	800	36	914		

Lug Style valves cover the bolting the entire length of the body. They are furnished in scallop and full body designs. Scallop is furnished no matter when possible to keep weight to a minimum. These valves are standard retainerless design. Lug valves can be specified with threaded or thru-hole bolting.

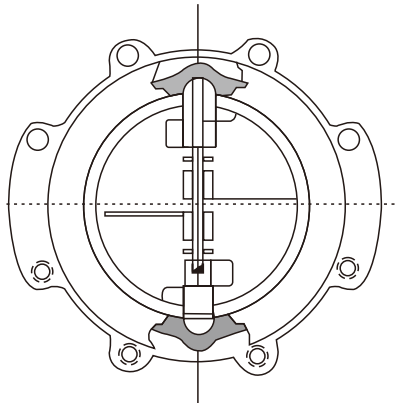

Scallop

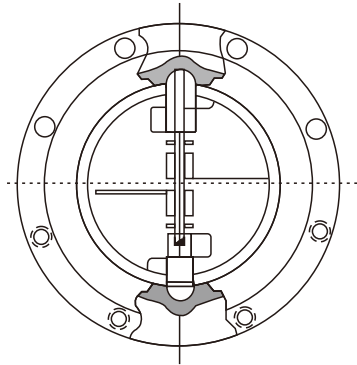

Full Body

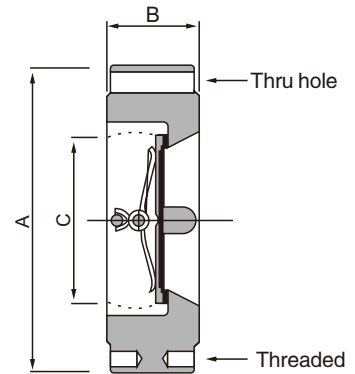

Flow Direction

● ASME Class 150

Size		A		B		C		Weight	
in	mm	in	mm	in	mm	in	mm	lbs.	kg.
2"	60	6-1/2	165	2-3/8	60	1-15/16	49	17	8
2 1/2"	65	7-1/2	191	2-5/8	67	2-11/32	60	17	8
3"	80	8-1/4	210	2-7/8	73	2-29/32	74	17	8
4"	100	9	229	2-7/8	73	3-53/64	97	28	13
5"	125	10	254	3-3/8	86	4-13/16	122	36	16
6"	150	11	279	3-7/8	98	5-49/64	146	48	22

● ASME Class 300

Size		A		B		C		Weight	
in	mm	in	mm	in	mm	in	mm	lbs.	kg.
2"	50	6-1/2	165	2-3/8	60	1-15/16	49	18	8
2 1/2"	65	7-1/2	191	2-5/8	67	2-11/32	60	22	10
3"	80	8-1/4	210	2-7/8	73	2-29/32	74	30	14
4"	100	10	254	2-7/8	73	3-53/64	97	36	16
5"	125	11	279	3-3/8	86	4-13/16	122	51	23
6"	150	12-1/2	318	3-7/8	98	5-49/64	146	84	38
8"	200	15	381	5	127	7-5/8	194	135	61
10"	250	17-1/2	445	5-3/4	146	9-9/16	243	270	123

● ASME Class 600

Size		A		B		C		Weight	
in	mm	in	mm	in	mm	in	mm	lbs.	kg.
2"	50	6-1/2	165	2-3/8	60	1-15/16	49	18	8
2 1/2"	65	7-1/2	191	2-5/8	67	2-11/32	60	22	10
3"	80	8-1/4	210	2-7/8	73	2-29/32	74	30	14
4"	100	10	273	3-1/8	79	3-53/64	97	51	23
6"	150	14	356	5-3/8	137	5-49/64	146	183	93
8"	200	16	419	6-1/2	165	7-5/8	194	295	134
10"	250	20	508	8-3/8	213	9-9/16	243	540	245

● ASME Class 900

Size		A		B		C		Weight	
in	mm	in	mm	in	mm	in	mm	lbs.	kg.
2"	50	8-1/2	216	2-3/4	70	1-11/16	43	37	17
3"	80	9-1/2	241	3-1/4	83	2-5/8	67	57	26
4"	100	11-1/2	292	4	102	3-7/8	87	98	45
6"	150	15	381	6-1/4	159	5-3/16	132	252	114
8"	200	18-1/2	470	8-1/8	206	6-13/16	173	441	200
10"	250	21-1/2	546	9-1/2	241	8-1/2	216	787	357

● ASME Class 1500

Size		A		B		C		Weight	
in	mm	in	mm	in	mm	in	mm	lbs.	kg.
2"	60	8-1/2	216	2-3/4	70	1-11/16	43	37	17
3"	80	10-1/2	267	3-1/4	83	2-5/8	67	70	32
4"	100	12-1/4	311	4	102	3-7/16	87	112	51
6"	150	15-1/2	394	6-1/4	159	5-3/16	132	262	119
8"	200	19	483	8-1/8	206	6-13/16	173	488	221
10"	250	23	584	9-3/4	248	8-1/2	216	917	416
12"	300	26-1/2	673	12	305	10-1/8	257	1425	646
14"	350	29-1/2	749	14	356	11-1/2	292	2045	928
16"	400	32-1/2	826	15-1/8	384	12-13/16	325	2600	1179
18"	450	36	914	18-7/16	468	13-3/4	349	3883	1761
20"	500	38-3/4	984	21	533	14-3/4	348	5700	2580
24"	600	46	1168	22	559	15-1/8	384	7150	3236

● ASME Class 2500

Size		A		B		C		Weight	
in	mm	in	mm	in	mm	in	mm	lbs.	kg.
2"	50	9-1/4	235	2-3/4	70	1-15/16	43	48	22
3"	80	12	305	3-3/8	86	2-5/8	67	93	42
4"	100	14	356	4-1/8	105	3-7/16	87	152	69
6"	150	19	483	6-1/4	159	5-3/16	132	386	175
8"	200	21-3/4	552	8-1/8	206	6-13/16	173	682	309
10"	250	26-1/2	673	10	254	8-1/2	216	1233	559
12"	300	30	762	12	305	10-1/8	257	1881	853

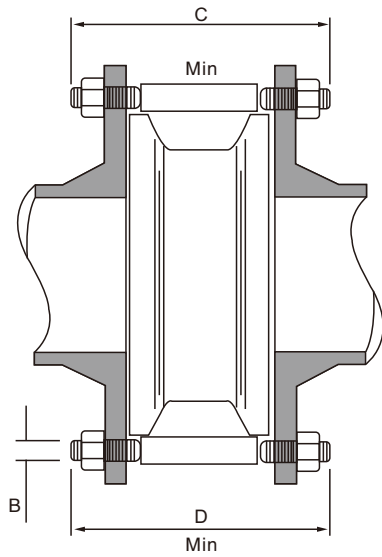

Ring Joint Flanges

● ASME Class 125

Valve Size		No. of Studs	B		C	
			Bolt Diameter		Flat Face	
in	mm		in	mm	in	mm
2"	50	4	5/8	16	5 ¹ / ₄	133
2 ¹ / ₂ "	65	4	5/8	16	5 ¹ / ₂	140
3"	80	4	5/8	16	5 ³ / ₄	146
4"	100	8	5/8	16	6 ¹ / ₄	159
5"	125	8	3/4	19	6 ³ / ₄	171
6"	150	8	3/4	19	7	178
8"	200	8	3/4	19	8	203
10"	250	12	7/8	22	9	229
12"	300	12	7/8	22	10 ¹ / ₂	267

● ASME Class 150

Valve Size		No. of Studs	B		C		D	
			Bolt Diameter		Raised Face		Ring Joint	
in	mm		in	mm	in	mm	in	mm
2"	50	4	5/8	16	5 ³ / ₄	146	6 ¹ / ₄	159
2 ¹ / ₂ "	65	4	5/8	16	6 ¹ / ₄	159	7	178
3"	80	4	5/8	16	6 ³ / ₄	171	7 ¹ / ₄	184
4"	100	8	5/8	16	6 ³ / ₄	171	7 ¹ / ₄	184
5"	125	8	3/4	19	7 ¹ / ₂	191	8	203
6"	150	8	3/4	19	8	203	8 ¹ / ₂	216
8"	200	8	3/4	19	9 ¹ / ₂	241	10	254
10"	250	12	7/8	22	10 ¹ / ₂	267	11	279
12"	300	12	7/8	22	12	305	12 ¹ / ₂	318
14"	350	12	1	25	12 ³ / ₄	324	13 ¹ / ₄	337
16"	400	16	1	25	13 ¹ / ₄	337	13 ³ / ₄	349
18"	450	16	1 ¹ / ₈	29	14 ¹ / ₄	362	14 ³ / ₄	375
20"	500	20	1 ¹ / ₈	29	15	381	15 ¹ / ₂	394
24"	600	20	1 ¹ / ₄	32	15 ³ / ₄	400	16 ¹ / ₄	413
26"	650	24	1 ¹ / ₄	32	22 ³ / ₄	578	23 ¹ / ₄	591
30"	750	28	1 ¹ / ₄	32	21 ¹ / ₄	540	22 ³ / ₄	578
36"	900	32	1 ¹ / ₂	38	26 ¹ / ₄	667	39	679
42"	1050	36	1 ¹ / ₂	38	28 ¹ / ₂	724		
48"	1200	44	1 ¹ / ₂	38	33	838		
54"	1350	44	1 ³ / ₄	44	35	889		
60"	1500	52	1 ³ / ₄	44				
66"	1650	52	1 ³ / ₄	44				
72"	1800	60	1 ¹ / ₈	29				

● ASME Class 300

Valve Size		No. of Studs	B		C		D	
			Bolt Diameter		Raised Face		Ring Joint	
in	mm		in	mm	in	mm	in	mm
2"	50	8	5/8	16	6	152	6 ³ / ₄	171
2 ¹ / ₂ "	65	8	3/4	19	6 ³ / ₄	171	7 ¹ / ₂	191
3"	80	8	3/4	19	7	178	8	203
4"	100	8	3/4	19	7 ¹ / ₂	191	8 ¹ / ₄	210
5"	125	12	3/4	19	8 ¹ / ₄	210	9	229
6"	150	12	3/4	19	9	229	9 ³ / ₄	248
8"	200	12	7/8	22	10 ¹ / ₂	267	11 ¹ / ₄	286
10"	250	16	1	25	12 ¹ / ₄	311	13	330
12"	300	16	1 ¹ / ₈	29	14	356	14 ³ / ₄	375
14"	350	20	1 ¹ / ₄	29	16	406	16 ³ / ₄	425
16"	400	20	1 ¹ / ₄	32	17	432	17 ³ / ₄	451
18"	450	24	1 ¹ / ₄	32	18 ¹ / ₂	470	19 ³ / ₄	489
20"	500	24	1 ¹ / ₂	32	19 ³ / ₄	502	20 ¹ / ₂	521
24"	600	24	1 ⁵ / ₈	38	21 ³ / ₄	552	22 ³ / ₄	578
26"	650	28	1 ³ / ₄	41	34 ¹ / ₄	616	25 ¹ / ₄	641
30"	750	28	1 ³ / ₄	44	27 ¹ / ₄	692	28 ¹ / ₂	724
36"	900	32	2	51	32 ¹ / ₄	819	15 ¹ / ₂	851
42"	1050	36	2	51	36 ¹ / ₂	927	37 ³ / ₄	959
48"	1200	40	2	51	40	1016		

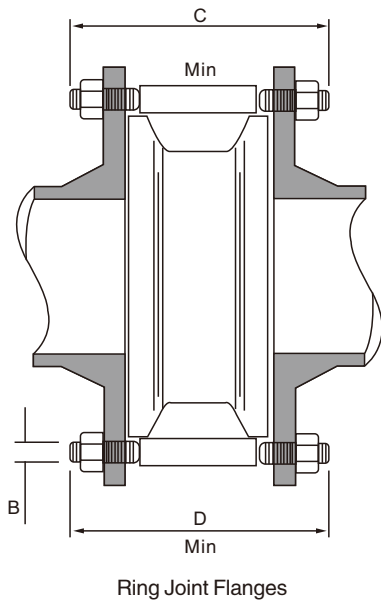

ASME Class 600

Valve Size		No. of Studs	B		C		D	
in	mm		Bolt Diameter	mm	Raised Face	mm	Ring Joint	mm
2"	50	8	5/8	16	6 ³ / ₄	171	7	178
2 1/2"	65	8	3/4	19	7 1/2	191	7 ³ / ₄	197
3"	80	8	3/4	19	8	203	8 1/4	210
4"	100	8	7/8	22	9 1/4	235	9 1/4	235
5"	125	8	1	25	10 ³ / ₄	273	11	279
6"	150	12	1	25	12 1/4	311	12 1/2	318
8"	200	12	1 1/8	29	14 1/4	362	14 1/2	368
10"	250	16	1 1/4	32	17	432	17 1/4	438
12"	300	20	1 1/4	35	18	457	18	457
14"	350	20	1 3/8	35	20 1/4	514	20 1/2	521
16"	400	20	1 1/2	38	22 1/4	565	22 1/2	572
18"	450	20	1 5/8	41	25 1/4	641	25 1/2	648
20"	500	24	1 5/8	41	26	660	26 1/4	667
24"	600	24	1 7/8	48	30 1/4	768	30 3/4	781
26"	650	28	1 7/8	48	31 1/2	800	32	813
30"	750	28	2	51	34 1/4	870	34 3/4	883
36"	900	28	2 1/2	64	41	1041	20 1/2	1060
42"	1050	28	2 3/4	70	47	1194	47 1/2	1207

ASME Class 900

Valve Size		No. of Studs	B		C		D	
in	mm		Bolt Diameter	mm	Raised Face	mm	Ring Joint	mm
2"	50	8	7/8	22	8 ³ / ₄	222	8 ³ / ₄	222
2 1/2"	65	8	1	25	9 ³ / ₄	248	9 ³ / ₄	248
3"	80	8	7/8	22	9 1/4	235	9 1/4	235
4"	100	8	1 1/8	29	11	279	11	279
6"	150	12	1 1/8	29	14	356	14	362
8"	200	12	1 3/8	35	17	432	17	438
10"	250	16	1 3/8	35	19	483	19	483
12"	300	20	1 3/8	35	21 3/4	552	21 3/4	552
14"	350	20	1 1/2	38	25	635	25 1/2	648
16"	400	20	1 5/8	41	26 3/4	679	27	686
18"	450	20	1 7/8	48	30 3/4	781	31 1/2	800
20"	500	20	2	51	31 1/2	800	32 1/4	819
24"	600	20	2 1/2	64	36 3/4	933	36 3/4	946

ASME Class 1500

Valve Size		No. of Studs	B		C		D	
in	mm		Bolt Diameter	mm	Raised Face	mm	Ring Joint	mm
2"	50	8	7/8	22	8 ³ / ₄	222	8 ³ / ₄	222
2 1/2"	65	8	1	25	9 ³ / ₄	248	9 ³ / ₄	248
3"	80	8	1 1/8	29	10 1/2	267	10 1/2	267
4"	100	8	1 1/4	32	12	305	12	305
6"	150	12	1 3/8	35	16 ³ / ₄	425	16 ³ / ₄	425
8"	200	12	1 5/8	41	19 ³ / ₄	502	20 1/4	514
10"	250	12	1 7/8	48	23 1/4	591	23 1/2	597
12"	300	16	2	51	27	686	27 ³ / ₄	705
14"	350	16	2 1/4	57	30 1/4	795	30 1/4	794
16"	400	16	2 1/2	64	33	838	34	864
18"	450	16	2 3/4	70	38 ³ / ₄	965	39	900
20"	500	16	3	76	43 ³ / ₄	1111	44 ³ / ₄	1137
24"	600	16	3 1/2	89	48 1/4	1219	49 1/4	1251

ASME Class 2500

Valve Size		No. of Studs	B		C		D	
in	mm		Bolt Diameter	mm	Raised Face	mm	Ring Joint	mm
2"	50	8	10	25	10	254	10	254
2 1/2"	65	8	1 1/8	29	11 1/4	286	11 1/4	286
3"	80	8	1 1/4	32	12 1/2	311	12 1/2	318
4"	100	8	1 1/2	38	14 1/4	362	14 3/4	375
6"	150	8	2	51	20	508	20 1/2	521
8"	200	12	2	51	23 3/4	603	24	610
10"	250	12	2 1/2	64	29 1/4	743	30 1/4	768
12"	300	12	2 3/4	70	33 1/4	845	34 1/4	870

● RECOMMENDED FLOW RATE RANGES

This chart is based on flow of clean water at ambient temperature. Consult our engineering department for pressure drop information for steam, gases or viscous fluids.

Piping practice recommends placement of check valve a distance equal to 5 pipe diameters from any turbulence producing device such as elbows, pumps, etc.

● HORIZONTAL INSTALLATION ONLY

Media	Flow Rate
Liquid	3 to 11 feet/second 0.91 to 3.35 m/second
Gas	20 to 250 feet/second 6.1 to 76.2 m/second

● CV and Cracking Pressure

Size	Cv	Cracking Pressure(psi)
2"	48	0.230
2.5"	77	0.260
3"	135	0.210
4"	270	0.220
5"	450	0.180
6"	720	0.140
8"	1400	0.190
10"	2600	0.180
12"	3850	0.170
14"	5000	0.150
16"	7250	0.160
18"	10000	0.150
20"	124000	0.130
24"	20400	0.100
30"	38000	0.080
36"	60000	0.080
42"	89000	0.050
48"	124000	0.060

Cv value

Cv indicates the gallons of water at temperature +60° F flowing through the valve bore in pressure differential down 1 Lbs/Inch 2 (0.0068694757Mpa).

● Pressure Drop Chart

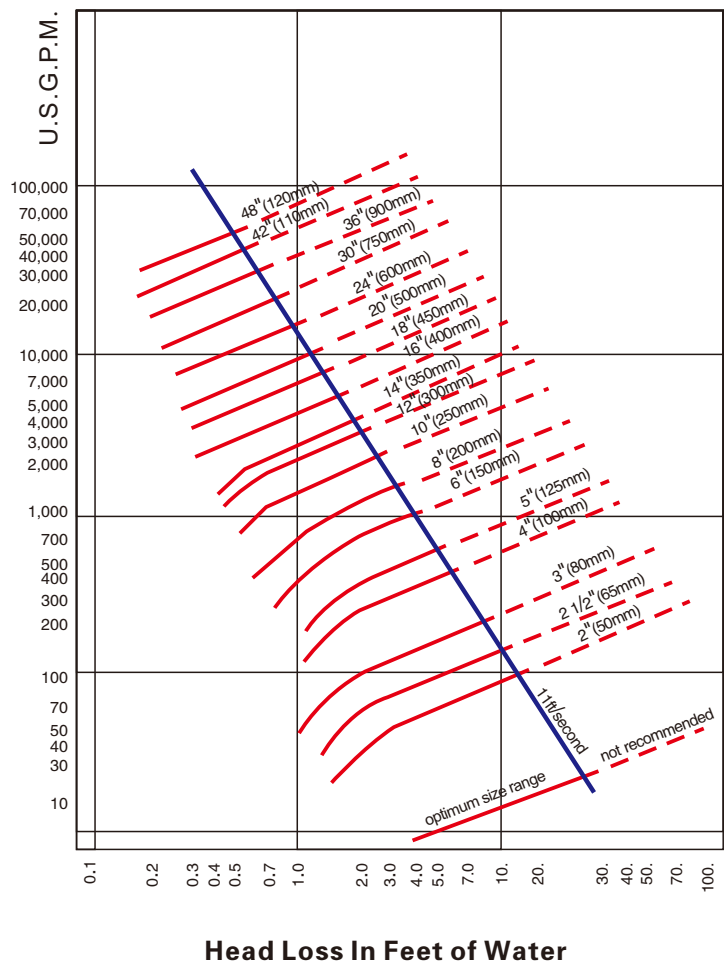

SIZE	TYPE	PRESSURE RATING	BODY/DISC MATERIAL	
			Suffix ASTM Grade	Category
2"	CI-Cast Iron	12-125#	W-WCB	01- Cast Steel
2 1/2"	CSR-Cast Steel, Rubber Seat	15-150#	A-A126-B	02- Cast Iron
3"	CSM-Cast Steel, Metal Seat	30-300#	F-CF8M	03- 316
4"	SSR-Stainless Steel, Rubber Seat	60-600#	CN-CN7M	04- Alloy 20
5"	SSM-Stainless Steel, Metal Seat	90-900#	C8-CF8	05- 304
6"		150-1500#	C3-CF3	06-304L
8"		250-2500#	CC-CF8-C	07- 347
10"			CT-CF8-T	08- 321
12"			D-CD4MCu	09- Duplex-SS
14"			CM-CF3M	10- 316L
16"			G8-CG8M	11- 317
18"			G3-CG3M	12- 317L
20"			HM-N12MV	13- Hastelloy B
24"			CW-CW12MW	14- Hastelloy C
30"			CY-CY40	15- Inconel
36"			L-LCC	16- LCC
			M1-M35-1	17- Monel
			M2-M35-2	18- Monel
			M3-M35-H	19- Monel
			CZ-CZ100	20- Nickel
			CK-CK3M CuN	21- 254SMO

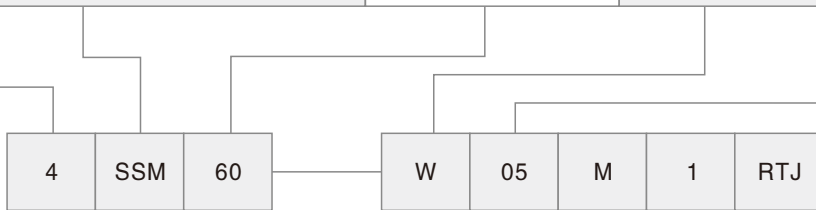

SEAT	SPRING	OPTIONS	Examples:
M-Metal B-Buna E-EPDM V-Viton T-Teflon	1-Inconel X-750 2-316 3-Monel 4-Hastelloy C 5-Alloy 20	RTJ-End Connection LUG-Lugged Body FE-Flanged Body NACE-NACE	To order a 4" 600# RTJ SS metal-seated Wafer Check valve with Inconel X-750 spring and 304 SS disc, use FIG. Number 4SSM60W05M1RTJ



API6D through conduit gate valve

**Add: Anfeng Industrial Zone, Oubei Town,
Wenzhou, Zhejiang Province 325105, China**

Tel: +86-577-67120997

Fax: +86-577-67120989

www.jscvalve.com

Email: sales@jscvalve.com