

|     |     |     |       |         |       |      |   |        |       |
|-----|-----|-----|-------|---------|-------|------|---|--------|-------|
| NPS | DN  | L   | øD    | øD1     | øD2   | C    | f | n-ød   | 4-M   |
| 36" | 900 | 330 | ø1170 | ø1085.8 | ø1022 | 90.9 | 2 | 28-ø42 | 4-M39 |

| Performance Standard |                     |             |
|----------------------|---------------------|-------------|
| Nominal CL (PN)      | 150LB               | Test medium |
| Shell test pressure  | 3.0MPa              | Water       |
| Seal test pressure   | 2.2MPa              |             |
| Air test pressure    | 0.6 MPa             | Air         |
| Suitable temperature | -29~300℃            |             |
| Suitable medium      | Water/Steam/Oil etc |             |

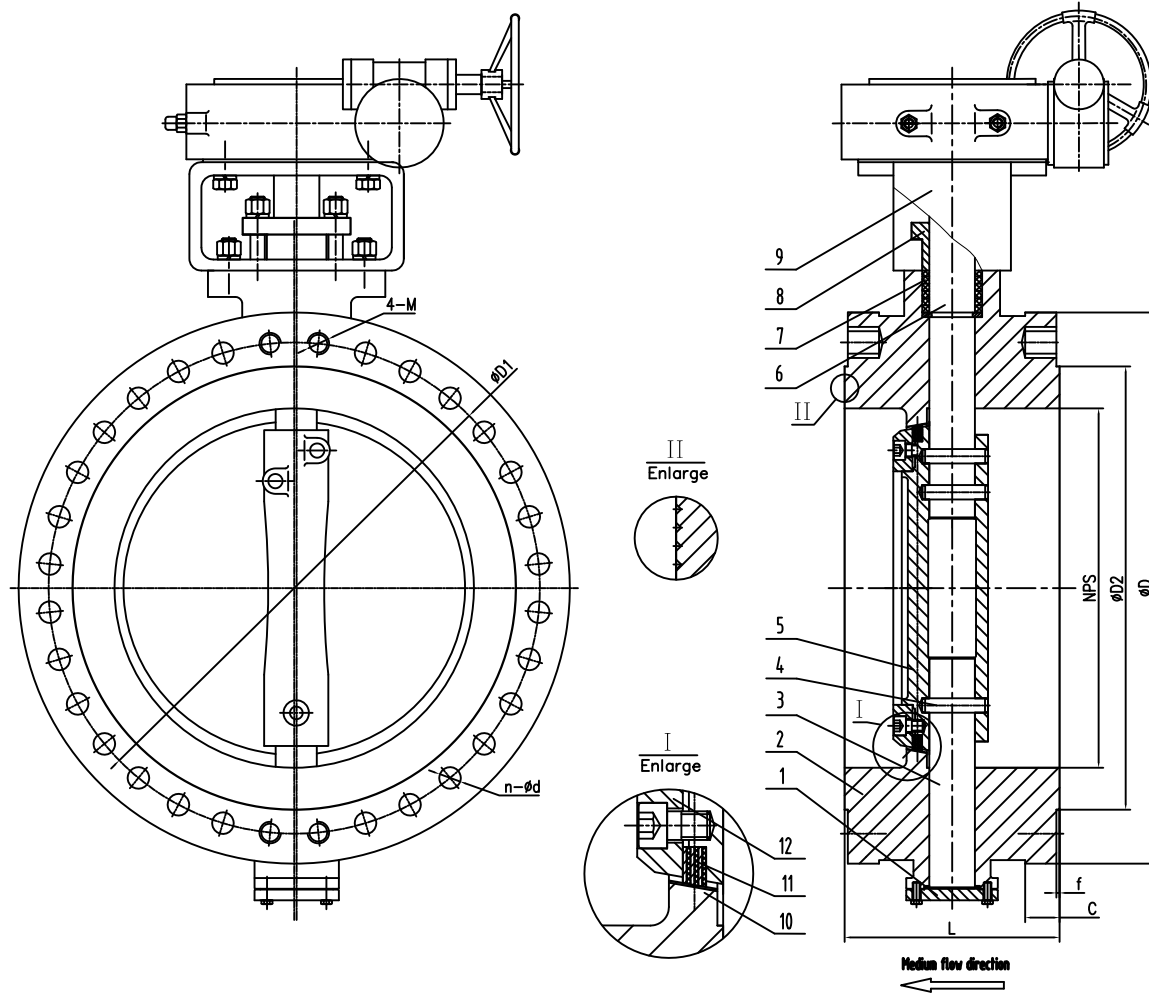

| 12  | Clamp Ring    | ASTM A182 F316         |        |
|-----|---------------|------------------------|--------|
| 11  | Sealing Ring  | ASTM A276 316+Graphite |        |
| 10  | Seat          | Surfacing 13Cr         |        |
| 9   | Yoke          | CS                     |        |
| 8   | Packing Gland | ASTM A216 WCB          |        |
| 7   | Packing       | Flexible Graphite      |        |
| 6   | Upper Shaft   | ASTM A564 630(17-4PH)  |        |
| 5   | Disc          | ASTM A351 CF8M         |        |
| 4   | Pin           | ASTM A182 F316         |        |
| 3   | Lower Shaft   | ASTM A564 630(17-4PH)  |        |
| 2   | Body          | ASTM A216 WCB          |        |
| 1   | Lower Cover   | ASTM A105              |        |
| NO. | PARTS NAME    | MATERIAL               | REMARK |

Triple Offset Butterfly Valve

|          |       |                        |                 |
|----------|-------|------------------------|-----------------|
| Size     | 36"   | Design&Manu            | API 609         |
| Class    | 150Lb | Inspection&Test        | API 598         |
| Rev.     | 00    | End Connection         | ASME B16.47A-RF |
| Man.Fig. |       | Face-to-face dimension | API 609         |

**Bosseal** Valves

Bosseal Valve(Suzhou) Co., Ltd