

Performance Sheet

Nominal Pressure		150LB	
Shell Test		3.0	
Water Test	Positive Seal Test	2.2	
	Reverse Seal Test	MPa	
Air Test	Positive Seal Test		
	Reverse Seal Test		
Suitable Temperature		-29~300t	
Suitable Medium		Water, Steam, Oil etc	

Technical Standard

- 1.Design conform to API 609
- 2.Face to face conform to API 609
- 3.Flange dimension conform to ASME B16.5
- 4.Test and inspect conform to API 598

12	Clamp Ring	ASTM A182 F304
11	Sealing Ring	ASTM A276 304+Graphite
10	Seat	Surfacing D507Mo
9	Yoke	CS
8	Packing Gland	ASTM A216 WCB
7	Packing	Flexible Graphite
6	Upper Shaft	ASTM A276 420
5	Disc	ASTM A216 WCB
4	Pin	ASTM A182 F304
3	Lower Shaft	ASTM A276 420
2	Body	ASTM A216 WCB
1	Lower Cover	ASTM A105
No	Parts Name	Parts Material

Bosseal Valve(Suzhou) Co., Ltd

Drawing NO:		BUTTERFLY VALVE	
6"D343H-150LB		150LB	
DRAWING BY	CHECKED BY	APPROVED BY	Date
D.Y.Z.	M.Z.H.	M.Z.H.	2022.06.30

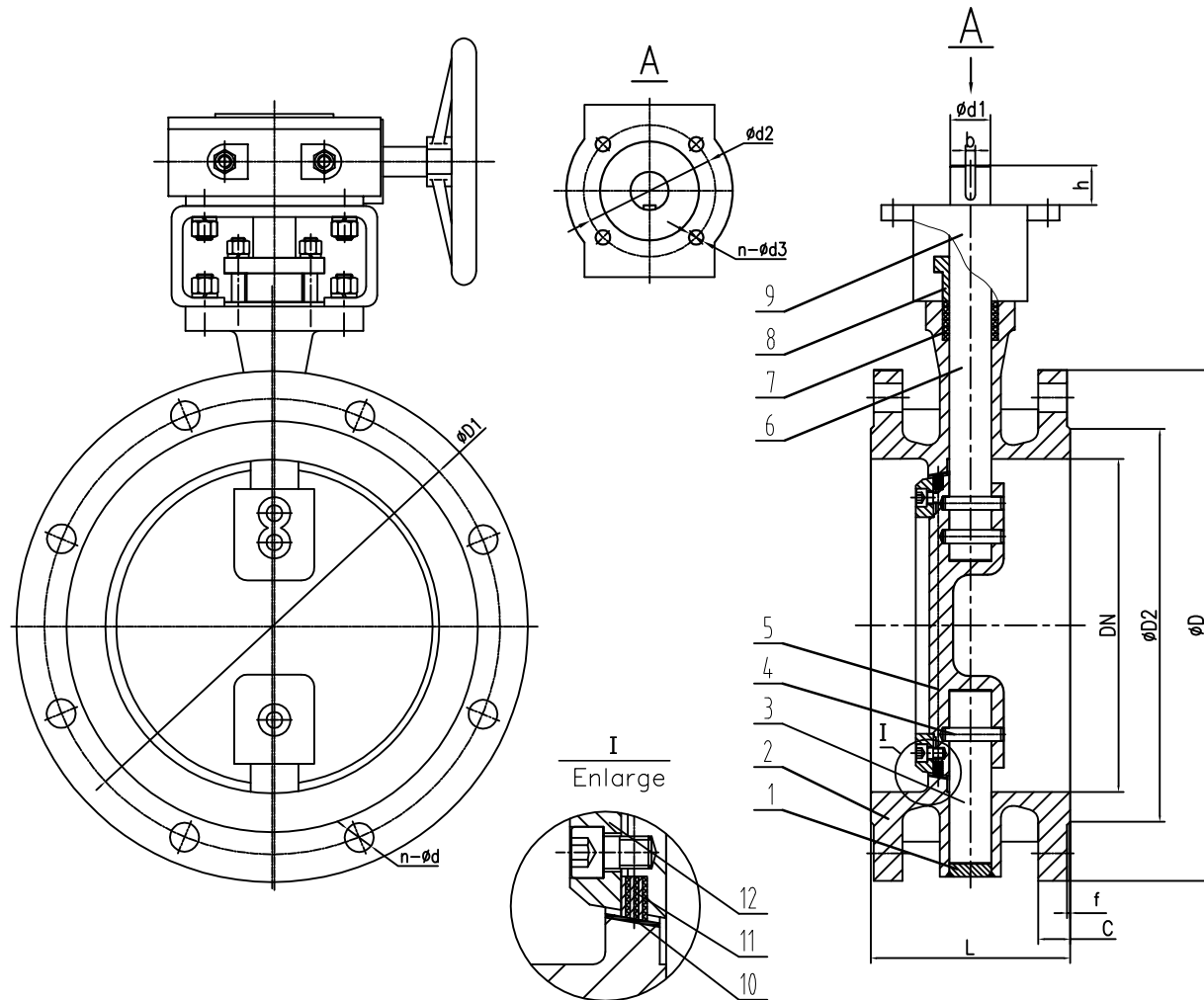

Bosseal Valves

NPS	DN	L	ϕD	$\phi D1$	$\phi D2$	C	f	$n-\phi d$	$\phi d1$	b	h	$\phi d2$	$n-\phi d3$
6"	150	140	$\phi 280$	$\phi 241.3$	$\phi 215.9$	25.9	2	8- $\phi 22$	$\phi 26$	1-8	45	$\phi 102$	4- $\phi 12$