

Performance Standard		
Nominal CL (PN)	300LB	Test medium
Shell test pressure	7.5MPa	Water
Seal test pressure	5.5MPa	
Air test pressure	0.6MPa	Air
Suitable temperature	-29~120℃	
Suitable medium	Water/Oil/Natural Gas etc	

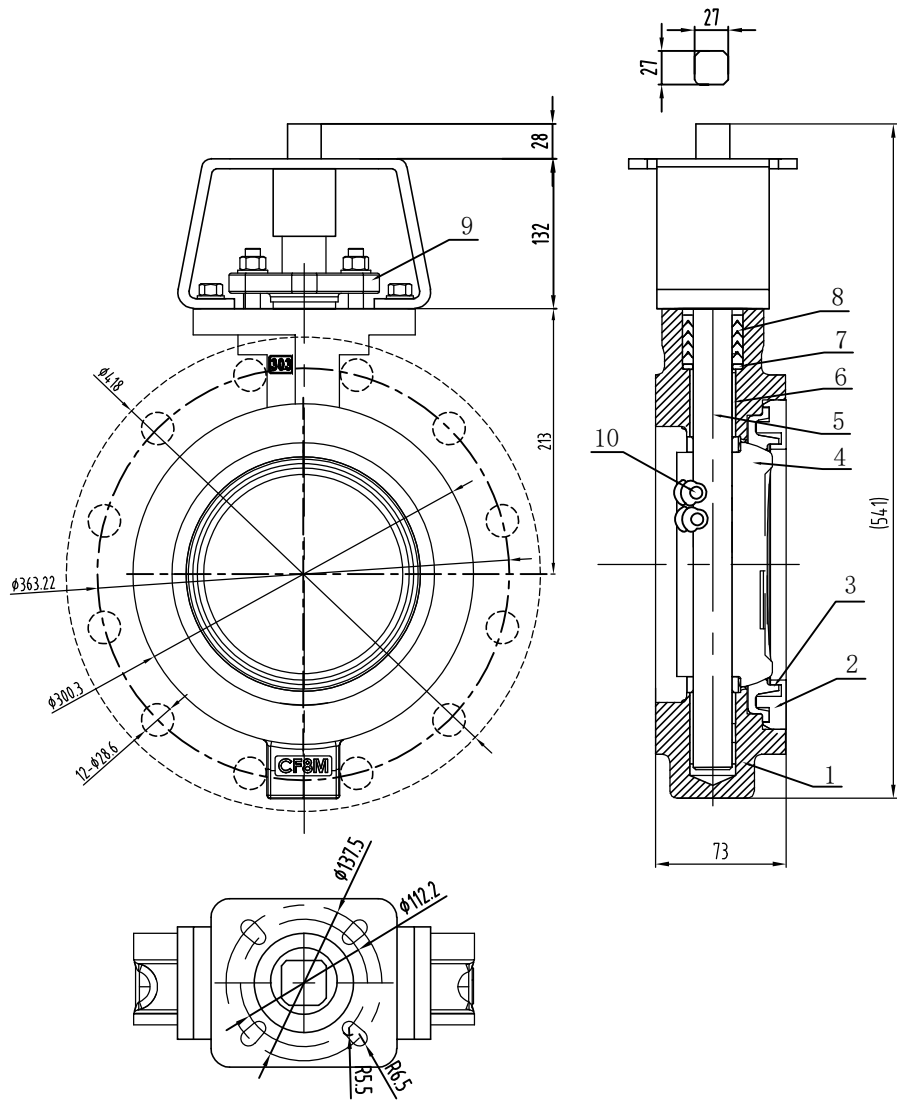

NO.	PARTS NAME	MATERIAL	REMARK
10	Pin	17-4PH	
9	Gland	CF8	
8	Parking	RPTFE	
7	Filler Gasket	316	
6	Bearing	316+RPTFE	
5	Drive Shaft	17-4PH	
4	Disc	CF8M	
3	Seat Ring	RPTFE	
2	Clamp Ring	CF8M	
1	Valve body	CF8M	

Double Offset Butterfly Valve - Wafer			
Size	8"	Design&Manu	API 609
Class	300Lb	Inspection&Test	API 598
Rev.	00	End Connection	ASME B16.5-Wafer
Man.Fig.		Face-to-face dimension	API 609

Bosseal Valves

Bosseal Valve(Suzhou) Co., Ltd