

ITEM NO.	SIZE	Dimension Unit: mm					Remarks
		L±1.6	d _{0.5} ⁺¹	D ₀ ^{+0.4}	L1±0.5	H±5	
18	1"	111.0	Ø17.5	Ø33.9	13.0	75.0	
19	1½"	152.0	Ø28.5	Ø48.8	13.0	97.0	

Performance Standard		
Nominal CL (PN)	800LB	Test medium
Shell test pressure	20.5MPa	Water
Seal test pressure	15.0MPa	
Air test pressure	/ MPa	Air
Suitable temperature	-29~400℃	
Suitable medium	Water/Steam/Oil etc	

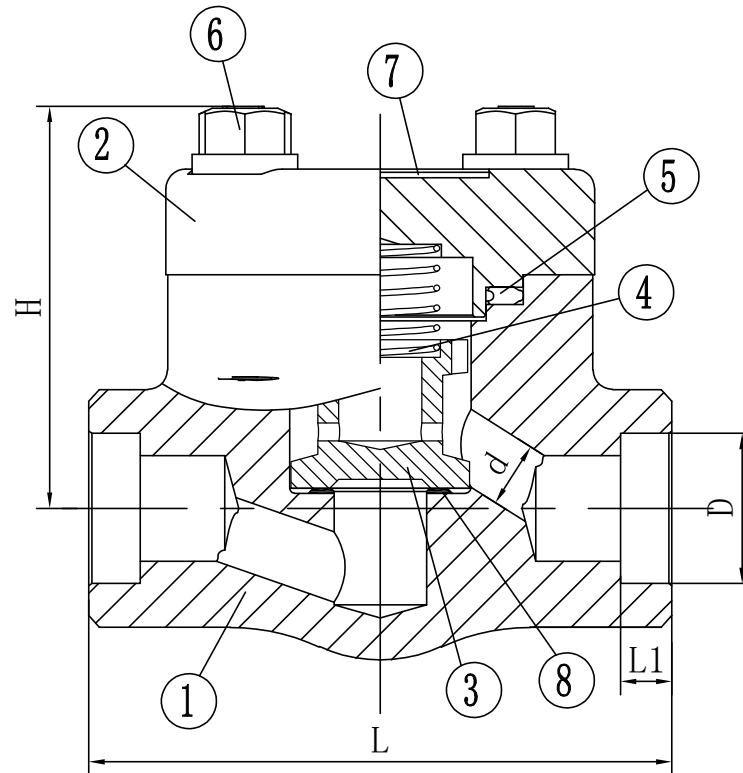

8	INTEGRAL SEAT	A105N+STL	
7	NAMEPLATE	Stainless Steel	
6	BONNET BOLT	A193 B7	
5	GASKET	316L+Graphite	
4	SPRING	316 SS	
3	DISC	A182 F6a	
2	BONNET	A105N	
1	BODY	A105N	
NO.	PARTS NAME	MATERIAL	REMARK

LIFTING CHECK VALVE

Size	1", 1-1/2"	Design&Manu	API 602
Class	800Lb	Inspection&Test	API 598
Rev.	00	End Connection	ASME B16.11-SW
Man.Fig.		Face-to-face dimension	MSG'S

Item No.	TAG No.	Weight/Kg≈
18	VCS4108G	3
19	VCS4108G	5.5

Bosseal Valves

Bosseal Valve(Suzhou) Co., Ltd