

ITEM NO.	SIZE	Dimension Unit: mm						Remarks
		L±1.6	d±0.5	D ₀ ^{+0.4}	L1±0.5	H±5	W±5	
8,30	3/4"	92.0	Ø13.0	Ø27.2	13.0	157.0	100.0	
9	1"	111.0	Ø18.0	Ø33.9	13.0	185.0	120.0	

Performance Standard		
Nominal CL (PN)	800LB	Test medium
Shell test pressure	20.5MPa	Water
Seal test pressure	15.0MPa	
Air test pressure	0.6 MPa	Air
Suitable temperature	-29~300℃	
Suitable medium	Water/Steam/Oil etc	

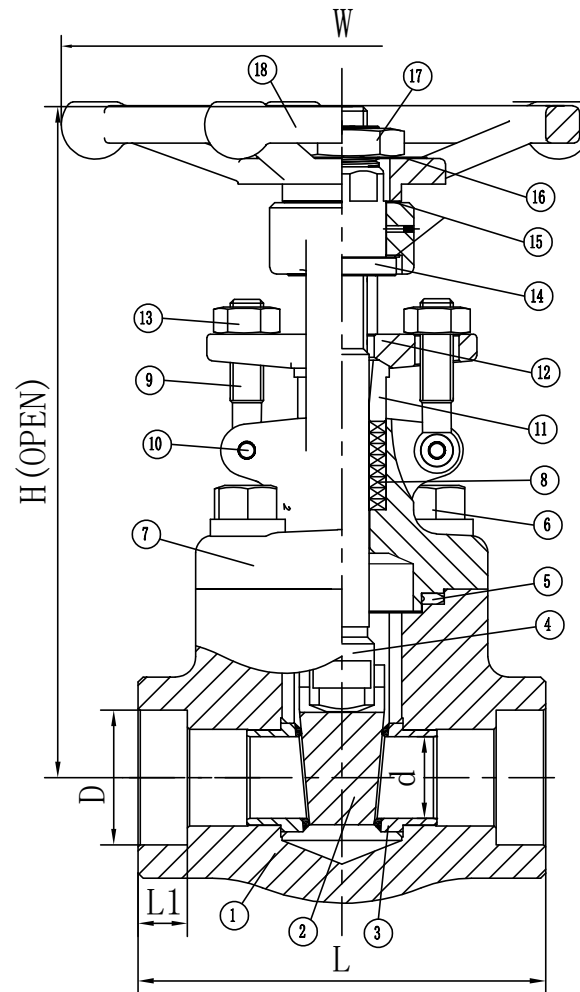

18	HAND WHEEL	A197	
17	HAND WHEEL NUT	A194 8M	
16	NAMEPLATE	Stainless Steel	
15	WASHER	A276 410	
14	STEM NUT	A276 410	
13	NUT	A194 8M	
12	GLAND FLANGE	A182 F316	
11	GLAND	A276 316	
10	GLAND BOLT PIN	A276 316	
9	GLAND BOLT	A193 B8M	
8	PACKING	Graphite	
7	BONNET	A182 F316	
6	BONNET BOLT	A193 B8M	
5	GASKET	316L+Graphite	
4	STEM	A182 F316	
3	SEAT RING	A182 F316+STL	
2	WEDGE	A182 F316	
1	BODY	A182 F316	
NO.	PARTS NAME	MATERIAL	REMARK

Gate Valve

Size	3/4",1"	Design&Manu	API 602
Class	800Lb	Inspection&Test	API 598
Rev.	00	End Connection	ASME B16.11-SW
Man.Fig.		Face-to-face dimension	MSG'S

Bosseal Valve(Suzhou) Co., Ltd

Bosseal Valves