

ITEM 1 2 3

3	800	2"	140	16	61.2	36	42	285	165	10
2	800	1"	111	13	33.9	18	22	202	115	4.1
1	800	3/4"	92	13	27.2	13.5	17	165	95	2.4
Item	CLASS	NPS	L	L1	E	d	D	H	W	G(Kg)

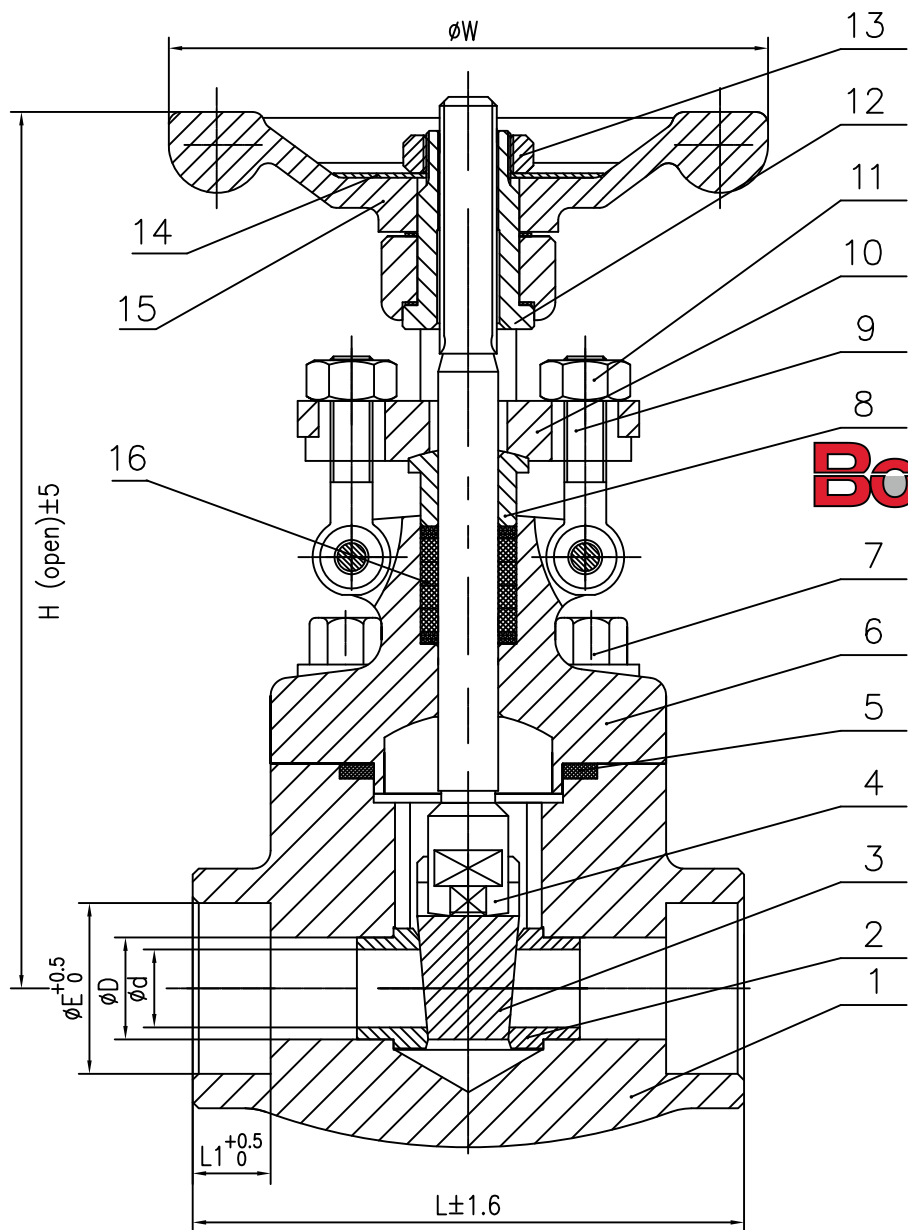

Bosseal Valves

16	Packing	Graphite
15	Handwheel	A 197
14	Nameplate	SS
13	H.W. Nut	C.S
12	Yoke Nut	ASTM 1035
11	Gland Nut	ASTM A194 2H
10	Gland Flange	ASTM A105N
9	Gland Eyebolt	ASTM A193 B7
8	Gland	ASTM A182 F6a
7	Hex. Bolt	ASTM A193 B7
6	Bonnet	ASTM A105N
5	Gasket	SS+Graphite
4	Stem	ASTM A182 F6a
3	Wedge	ASTM A182 F6a
2	Seat Ring	ASTM A182 F6a+STL
1	Body	ASTM A105N
No.	Part Name	Material

Gate Valve CLASS 800-SW

Design and Manufacture	API 602
Face to Face Dimensions	MFG'S
End Connection	ASME B16.11
Pressure-temperature	ASME B16.34
Test & Inspect	API 598
OTHER REQ.	

CLASS	800		
TEST	SHELL	21.4	MPa
	SEAT	15.4	
	BACKSEAT	15.4	
	AIR	0.6	
TEMPERATURE: -29~425°C			
MEDIUM: WATER, OIL, GAS, ETC.			

Bosseal Valve(Suzhou) Co., Ltd