

ITEM NO.	SIZE	Dimension Unit: mm						Remarks
		L±1.6	d±0.5	D <sub>0</sub> <sup>+0.4</sup>	L1±0.5	H±5	W±5	
11	1/2"	79.0	Ø13.0	Ø21.8	10.0	157.0	100.0	

Performance Standard		
Nominal CL (PN)	800LB	Test medium
Shell test pressure	20.5MPa	Water
Seal test pressure	15.0MPa	
Air test pressure	0.6 MPa	Air
Suitable temperature	-29~400℃	
Suitable medium	Water/Steam/Oil etc	

# Bosseal Valves

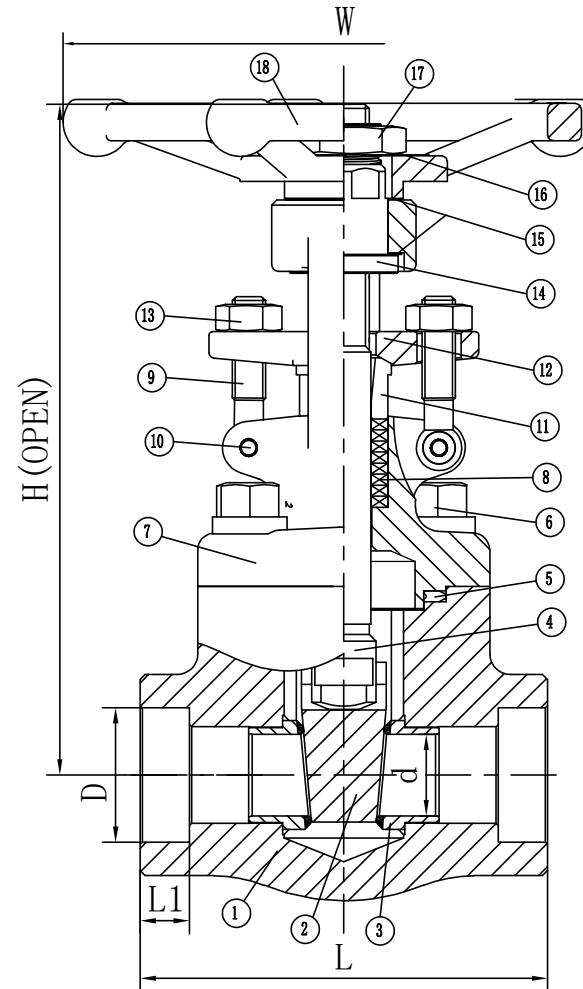

18	HAND WHEEL	A197	
17	HAND WHEEL NUT	A108 1020	
16	NAMEPLATE	<b>Stainless Steel</b>	
15	WASHER	A276 410	
14	STEM NUT	A276 410	
13	NUT	A194 2H	
12	GLAND FLANGE	A105N	
11	GLAND	A276 420	
10	GLAND BOLT PIN	A276 304	
9	GLAND BOLT	A193 B7	
8	PACKING	Graphite	
7	BONNET	A105N	
6	BONNET BOLT	A193 B7	
5	GASKET	304+Graphite	
4	STEM	A182 F6a	
3	SEAT RING	A182 F6a+STL	
2	WEDGE	A182 F6a	
1	BODY	A105N	
NO.	PARTS NAME	MATERIAL	REMARK

## Gate Valve

Size	1/2"	Design&Manu	API 602
Class	800Lb	Inspection&Test	API 598
Rev.	00	End Connection	ASME B16.11-SW
Man.Fig.		Face-to-face dimension	MSG'S

Bosseal Valve(Suzhou) Co., Ltd

Item No.	TAG No.
11	VAS4108G