

ITEM NO.	SIZE	Dimension Unit: mm						Remarks
		L±1.6	d±0.5	D <sub>0</sub> <sup>+0.4</sup>	L1±0.5	H±5	W±5	
8,30	3/4"	92.0	Ø13.0	Ø27.2	13.0	157.0	100.0	
9	1"	111.0	Ø18.0	Ø33.9	13.0	185.0	120.0	

Performance Standard		
Nominal CL (PN)	800LB	Test medium
Shell test pressure	20.5MPa	Water
Seal test pressure	15.0MPa	
Air test pressure	0.6 MPa	Air
Suitable temperature	-29~300℃	
Suitable medium	Water/Steam/Oil etc	

# Bosseal Valves

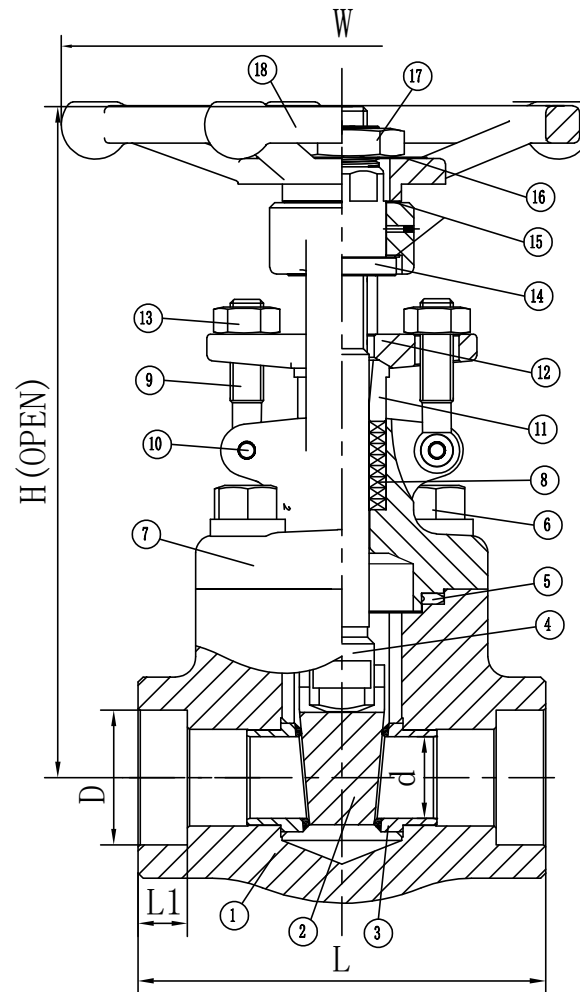

18	HAND WHEEL	A197	
17	HAND WHEEL NUT	A194 8	
16	NAMEPLATE	Stainless Steel	
15	WASHER	A276 410	
14	STEM NUT	A276 410	
13	NUT	A194 8	
12	GLAND FLANGE	A182 F304	
11	GLAND	A276 304	
10	GLAND BOLT PIN	A276 304	
9	GLAND BOLT	A193 B8	
8	PACKING	Graphite	
7	BONNET	A182 F304	
6	BONNET BOLT	A193 B8	
5	GASKET	316L+Graphite	
4	STEM	A182 F304	
3	SEAT RING	A182 F304+STL	
2	WEDGE	A182 F304	
1	BODY	A182 F304	
NO.	PARTS NAME	MATERIAL	REMARK

Gate Valve			
Size	3/4",1"	Design&Manu	API 602
Class	800Lb	Inspection&Test	API 598
Rev.	00	End Connection	ASME B16.11-SW
Man.Fig.		Face-to-face dimension	MSG'S

Bosseal Valve(Suzhou) Co., Ltd

Item No.	TAG No.
8,30	VAS4202G
9	VAS4202G