

ITEM 8 9 10 11

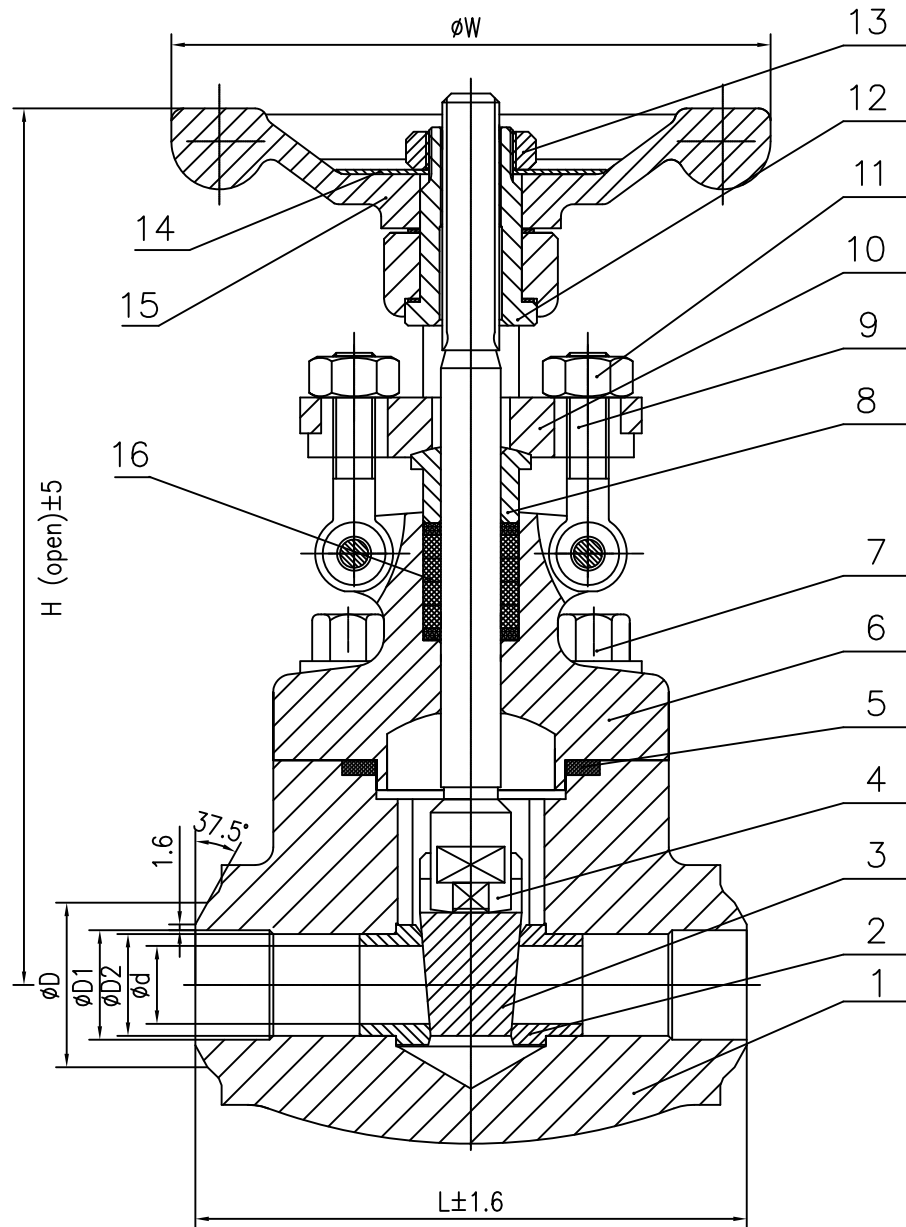

11	1500	2"	178	60.3	49.3	36	42	330	220	14
10	1500	1.1/2"	140	48.3	38.1	29	35	283	178	10
9	1500	1"	120	33.4	24.4	18	22	230	156	5.5
8	1500	3/4"	111	26.7	18.8	13.5	17	207	120	4.1
Item	CLASS	NPS	L	D	D1	d	D2	H	W	G(Kg)

16	Packing	Graphite
15	Handwheel	A 197
14	Nameplate	SS
13	H.W. Nut	C.S
12	Yoke Nut	ASTM A276 410
11	Gland Nut	ASTM A194 7
10	Gland Flange	ASTM A105N
9	Gland Eyebolt	ASTM A193 B16
8	Gland	ASTM A182 F6a
7	Hex. Bolt	ASTM A193 B16
6	Bonnet	ASTM A182 F22
5	Gasket	SS+Graphite
4	Stem	ASTM A182 F6a
3	Wedge	ASTM A182 F6a+STL
2	Seat Ring	ASTM A182 F6a+STL
1	Body	ASTM A182 F22
No.	Part Name	Material

Gate Valve CLASS 1500-BW -SCH80

Design and Manufacture	API 602
Face to Face Dimensions	MFG'S
End Connection	ASME B16.25
Pressure-temperature	ASME B16.34
Test & Inspect	API 598
OTHER REQ.	

CLASS	1500		
TEST	SHELL	37.5	MPa
	SEAT	27.5	
	BACKSEAT	27.5	
	AIR	0.6	

TEMPERATURE: -29-500°C
MEDIUM: WATER, OIL, GAS, ETC.

Bosseal Valve(Suzhou) Co., Ltd

Bosseal Valves