

Specification Standard Sheet(150LB)	
Shell Test Pressure	3.0
High Pressure Seal Test	2.2
Back Seat Seal Pressure Test	2.2
Low Pressure Seal Test	0.6
MPa	
TEMPERATURE: -29~300°C	
MEDIUM: WATER, OIL, GAS, ETC.	

Item	Nominal Diameter		Main Dimension mm									
	Inch	mm	L	D	D1	D2	Z- ϕ d	T	f	d	H	W
3	1"	25	127	110	79.4	50.8	4- ϕ 16	11.6	2	18	202	115

TAG No.	HV-1200-049/1	HV-1200-128/1	HV-1200-0438/1	HV-1200-127/1
		HV-1200-049/2	HV-1200-128/2	HV-1200-043/2

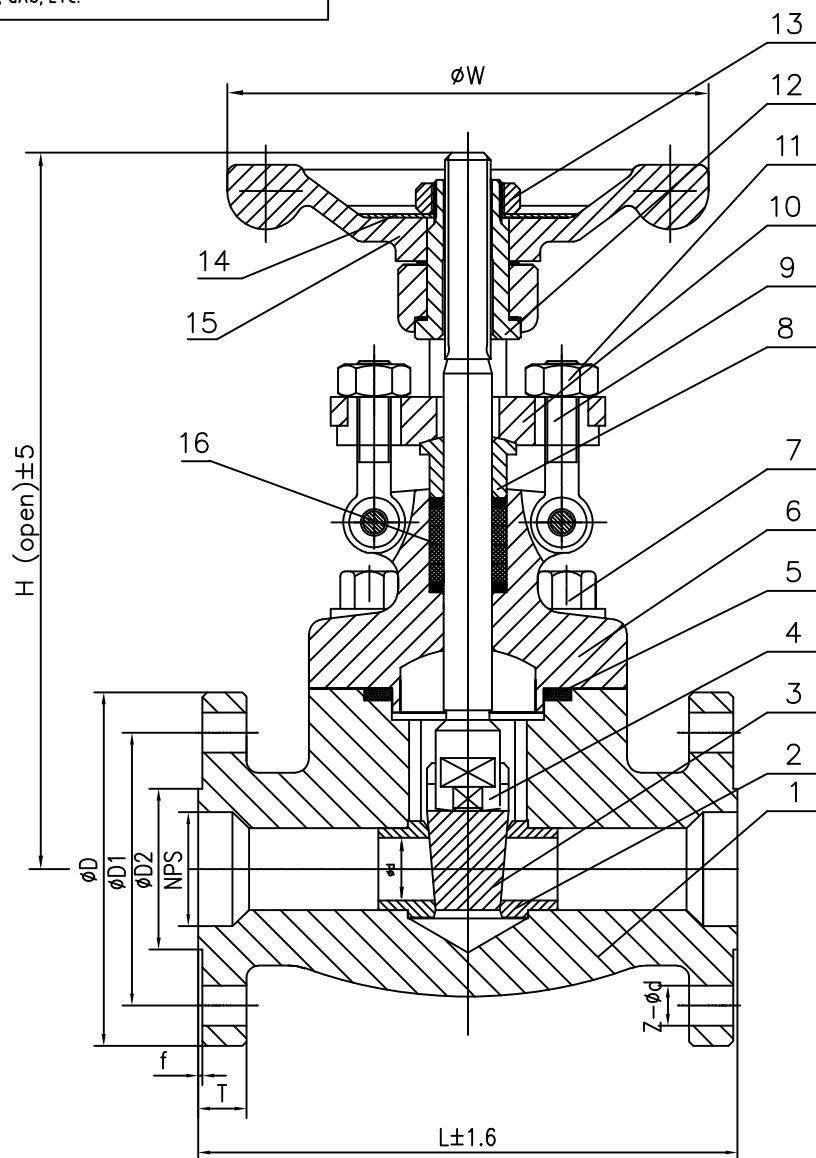

16	Packing	Graphite
15	Handwheel	A 197
14	Nameplate	SS
13	H.W. Nut	C.S
12	Yoke Nut	ASTM A276 410
11	Gland Nut	ASTM A194 8M
10	Gland Flange	ASTM A182 F304
9	Gland Eyebolt	ASTM A193 B8M
8	Gland	ASTM A182 F304
7	Hex. Bolt	ASTM A193 B8M
6	Bonnet	ASTM A182 F304
5	Gasket	SS+GRAPHITE
4	Stem	ASTM A182 F304
3	Wedge	ASTM A182 F304
2	Seat Ring	ASTM A182 F304
1	Body	ASTM A182 F304
No.	Part Name	Material

GATE VALVE, 1", CLASS150 RF

Temperature and Pressure	ASME B16.34
Design and Manufacture	API 602 B16.34
Face to Face Dimensions	ASME B16.10
Flanged Fittings Dimensions	ASME B16.5
Inspection and Test	API 598

Bosseal Valve(Suzhou) CO.,LTD

BossealValves