

2500	1"	182	13	33.9	18	22
CLASS	NPS	L	L1	E	d	D

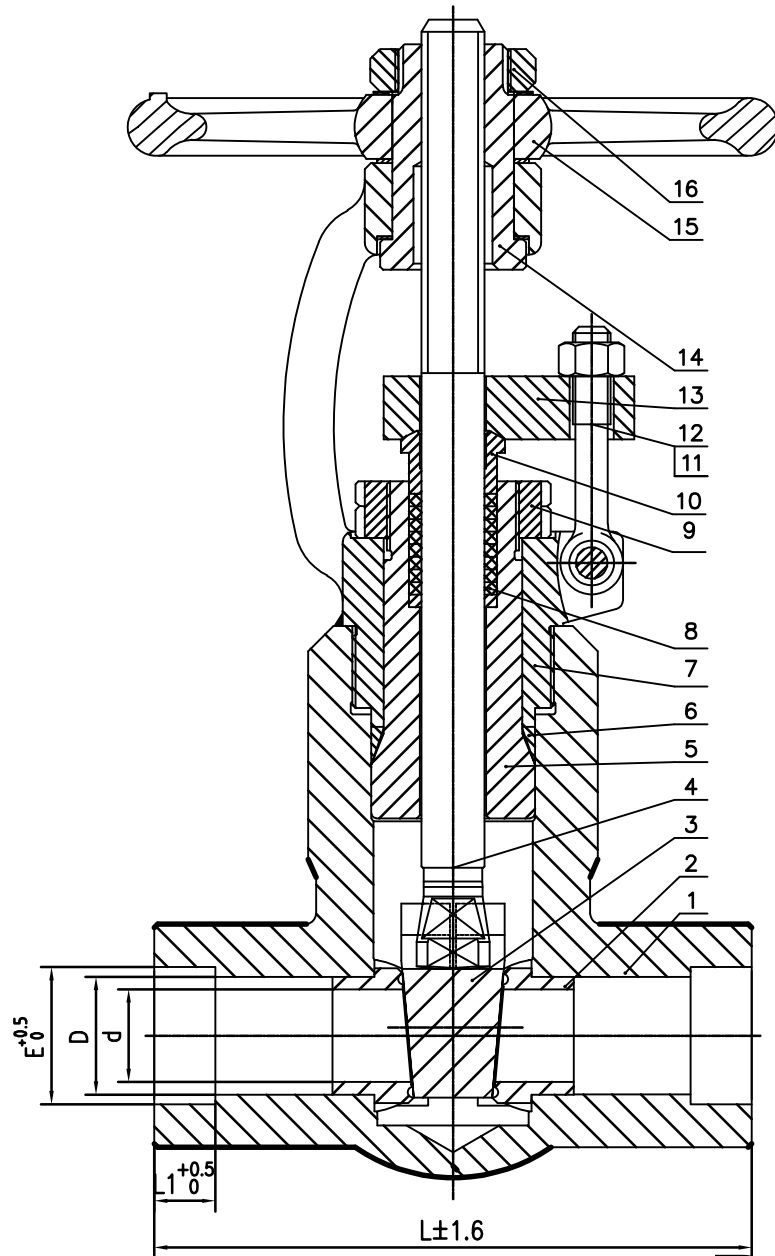

Performance Standard		
Nominal CL (PN)	2500LB	Test medium
Shell test pressure	63.0MPa	Water
Seal test pressure	46.2MPa	
Air test pressure	0.6 MPa	Air
Suitable temperature	-29~500℃	
Suitable medium	Water/Steam/Oil etc	

PO item: 11

TAG: VGASP01BSWF1G2V

16	H.W. Nut	C.S	
15	Hand Wheel	ASTM A197	
14	Stem Nut	ASTM A276 410	
13	Stuffing cover	ASTM A182 F11	
12	GAG	ASTM A194 7	
11	Eyebolt	ASTM A193 B16	
10	Gland	ASTM A276 410	
9	Nut	C.S	
8	Packing	Flexible Graphite+inconel wire	
7	Bonnet	ASTM A182 F11	
6	Gasket	SS316	
5	P.S Seat	ASTM A276 410	
4	Stem	ASTM A182 F304	
3	Wedge	ASTM A182 F304+STL	
2	Seat Ring	ASTM A182 F304+STL	
1	Body	ASTM A182 F11	
NO.	PARTS NAME	MATERIAL	REMARK

GATE VALVE CLASS 2500

Size	1"	Design&Manu	ASME B16. 34
Class	2500Lb	Inspection&Test	API 598
Rev.	00	End Connection	ASME B16.11-SW
Man.Fig.		Face-to-face dimension	MFG'S

**Bosseal** Valves

Bosseal Valve(Suzhou) Co., Ltd