

VALVE SIZE	DIMENSION mm.					
	L	D1	D2	K	z-Ød	F
8"-150LB	127	219	298.5	269.9	8-Ø22	1.6

Performance Standard		
Nominal CL (PN)	150LB	Test medium
Shell test pressure	3.0MPa	Water
Seal test pressure	2.2MPa	
Air test pressure	- MPa	Air
Suitable temperature	-29~120°C	
Suitable medium	Water/Steam/Oil etc	

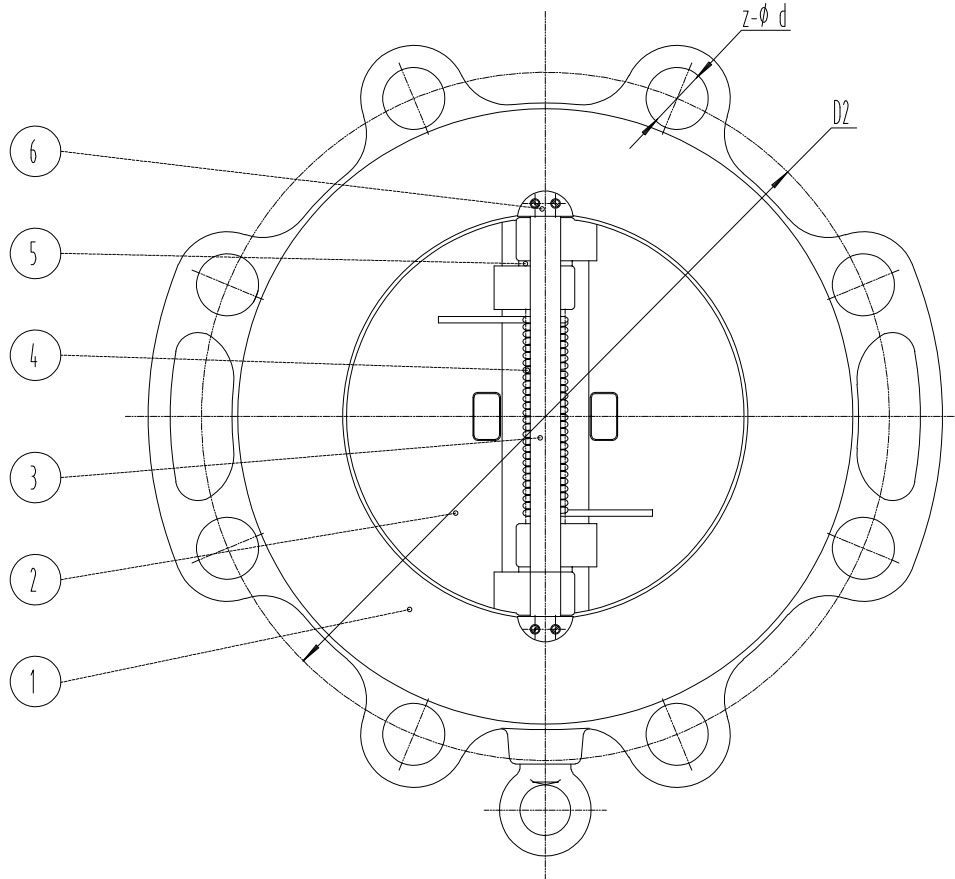
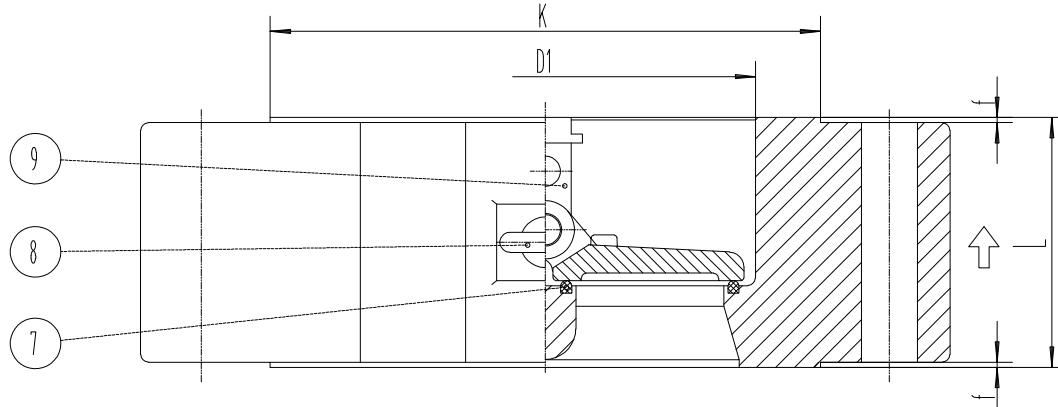

Bosseal Valves

9	Pin Holder	ASTM A995 6A	
8	Eye Bolt	Stainless Steel	
7	Seat	Int+STL	
6	Holder Lock	ASTM A182 F55	
5	Bearing	ASTM A182 F55	
4	Spring	INCONEL X-750	
3	Pin	ASTM A182 F53	
2	Plate	ASTM A995 6A	
1	Body	ASTM A995 6A	
NO.	PARTS NAME	MATERIAL	REMARK

Lug Type Dual Plate Check Valve

Size	8"	Design&Manu	API 594
Class	150Lb	Inspection&Test	API 598
Rev.	00	End Connection	ASME B16.5 -LUG
Man.Fig.		Face-to-face dimension	API 594

Bosseal Valve(Suzhou) Co., Ltd