

Performance Standard		
Nominal CL (PN)	300LB	Test medium
Shell test pressure	7.67MPa	Water
Seal test pressure	5.6MPa	
Air test pressure	-MPa	Air
Suitable temperature	-29~300℃	
Suitable medium	Water/Steam/Oil etc	

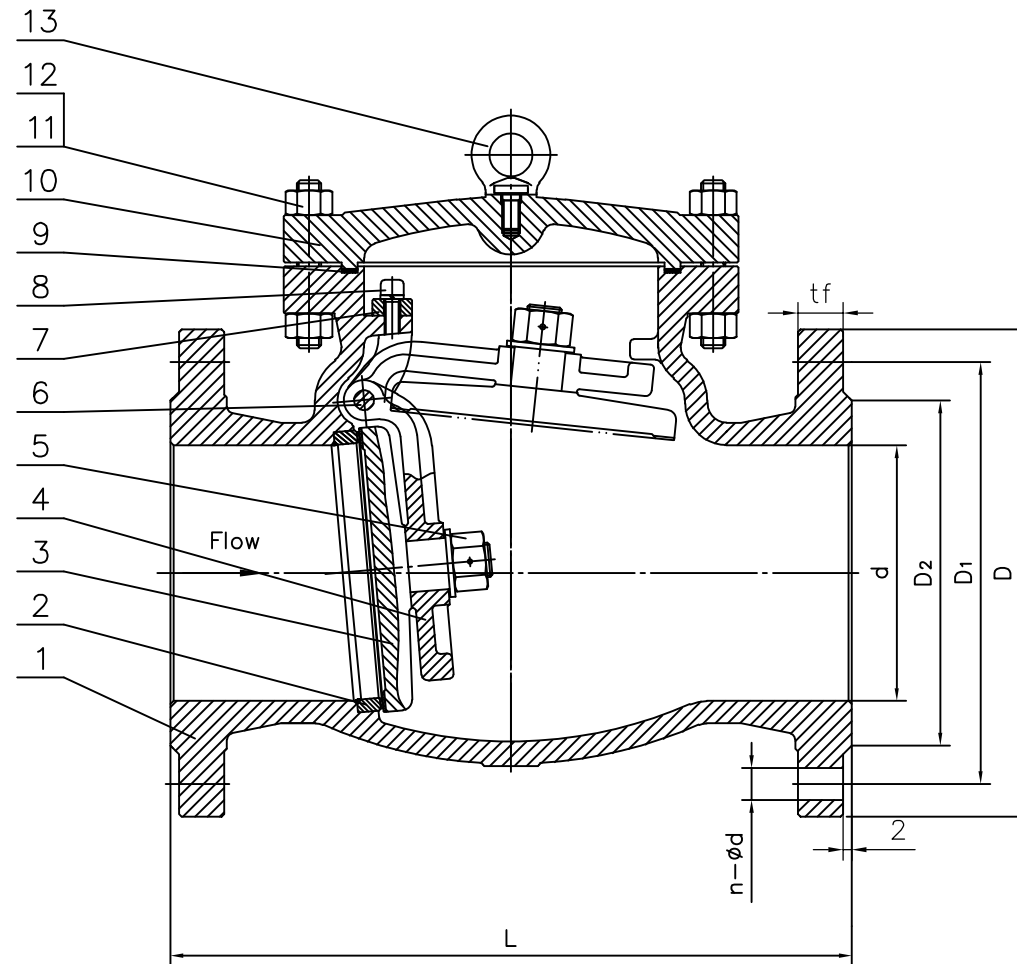

13	Eye Bolt	Carbon Steel	
12	Cover Bolt	ASTM A193 B7	
11	Cover Nut	ASTM A194 2H	
10	Cover	ASTM A216 WCB	
9	Winded Gasket	Graphite+SS316	
8	Yoke Bolt	ASTM A193 B8M	
7	Yoke	ASTM A216 WCB	
6	Pin	UNS B564 N04400	
5	Disc Nut	ASTM A194 8M	
4	Hinge	ASTM A216 WCB	
3	Disc	ASTM A494 M35-1	
2	Seat Ring	UNS B564 N04400	
1	Body	ASTM A216 WCB	
NO.	PARTS NAME	MATERIAL	REMARK

API 6D Swing Check Valve

Size	24"	Design&Manu	API 6D
Class	150Lb	Inspection&Test	API 598
Rev.	00	End Connection	ASME B16.5
Man.Fig.		Face-to-face dimension	ASME B16.10

Bosseal Valves

Bosseal Valve(Suzhou) Co., Ltd