

Performance Standard		
Nominal CL (PN)	600 (100)	Test medium
Shell test pressure	15.0MPa	Water
Seal test pressure	11.0MPa	
Air test pressure	—	Air
Suitable temperature	-29~425℃	
Suitable medium	Water/Steam/Oil etc	

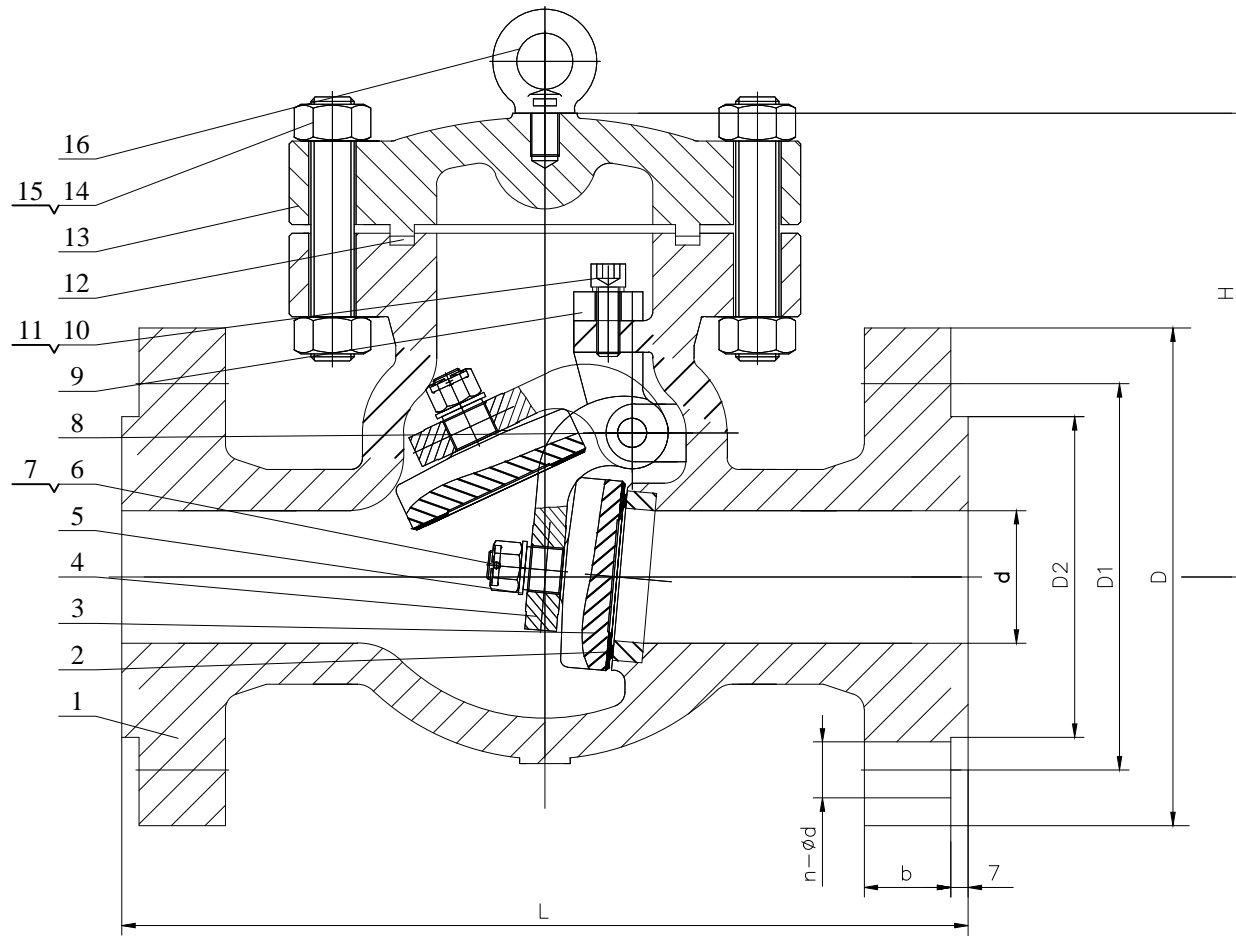

NO.	NPS	DN	L	d	D	D1	D2	z-φd	b	H
11	18	450	1092	φ419	φ745	φ654	φ533.4	20-φ44.5	82.6	596
12	20	500	1194	φ464	φ815	φ723.9	φ584.2	24-φ44.5	88.9	662

16	Hoisting bolt	A29 1035	
15	Cover Nut	A194 2H	
14	Cover Bolt	A193 B7	
13	Cover	A216 WCB	
12	Gasket	SS304+Graphite	
11	Bolt	A29 1035	
10	Spring washer	65Mn	
9	Yoke	A216 WCB	
8	Cylindrical pin	A182 F6a	
7	Cotter pin	SS304	
6	Disc Nut	A194 2H	
5	Disc Washer	A29 1035	
4	Rocker Arm	A216 WCB	
3	Disc	A216 WCB+13Cr	
2	Seat	A105+13Cr	
1	Body	A216 WCB	

NO	PART NAME	MATERIAL	REMARKS
----	-----------	----------	---------

SWING CHECK VALVE

Size	18",20"	Design&Manu	BS 1868
Class	600Lb	Inspection&Test	API 598
Rev.	00	End Connection	ASME B16.5 RF
Man.Fig.		Face-to-face dimension	ASME B16.10



Bosseal Valve(Suzhou) Co., Ltd