

Nominal Diameter		Main Dimension (mm)						
inch	mm	d	D	D1	D2	tf	n- ϕ d	L
16"	400	387	650	571.5	469.9	55.6	20- ϕ 35	838

Bosseal Valves

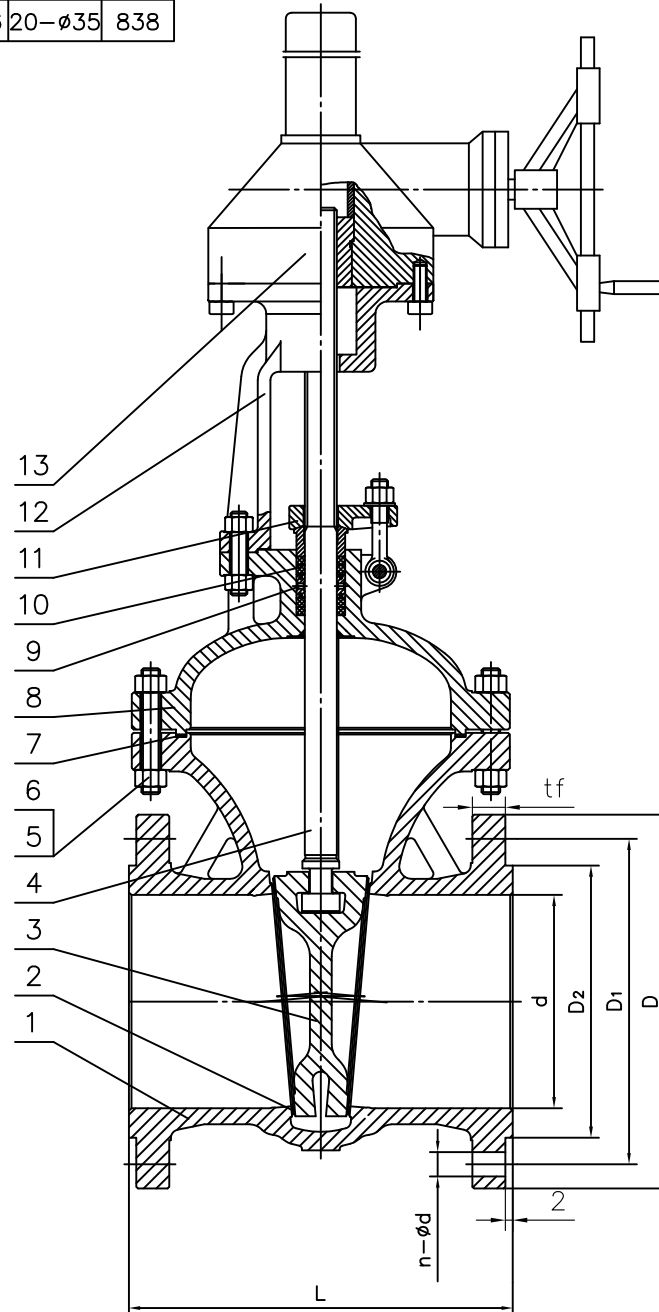

Performance Standard		
Nominal CL (PN)	300LB	Test medium
Shell test pressure	7.67MPa	Water
Seal test pressure	5.6MPa	
Air test pressure	0.6 MPa	Air
Suitable temperature	-29~340℃	
Suitable medium	Water/Steam/Oil etc	

13	Gear Actuator	ASSEMBLY	
12	Yoke	ASTM A351 CF8	
11	Gland Flange	ASTM A351 CF8	
10	Stem Packing	Flexible Graphite	
9	Packing Ring	ASTM A276 304	
8	Bonnet	ASTM A351 CF8+STL	
7	Winded Gasket	Graphite+SS304	
6	Bonnet Nut	ASTM A194 8	
5	Bonnet Bolt	ASTM A193 B8 CL.2	
4	Stem	ASTM A182 F304	
3	Flexible Wedge	ASTM A351 CF8	
2	Valve Seal	INT+STL6	
1	Body	ASTM A351 CF8	
NO.	PARTS NAME	MATERIAL	REMARK

Gate Valve

Size	16"	Design&Manu	API 600
Class	300Lb	Inspection&Test	API 598
Rev.	00	End Connection	ASME B16.5-RF
Man.Fig.		Face-to-face dimension	ASME B16.10

Bosseal Valve(Suzhou) Co., Ltd