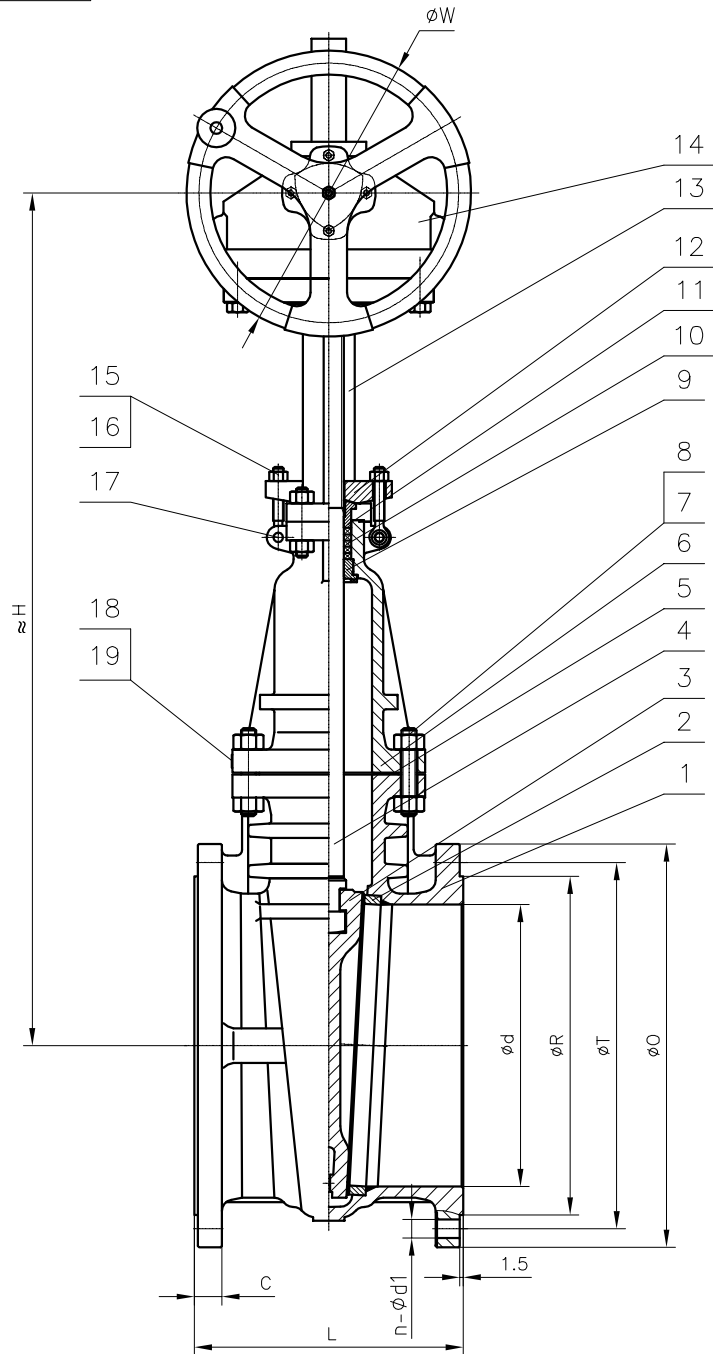

FIG.NO:



PARTS & MATERIAL LIST

ITEM	PART NAME	QTY	MATERIAL	NOTES
1	Body	1	ASTM A216 GR.WCB	
2	Seat Ring	2	ASTM A105N+STL#6	
3	Wedge	1	ASTM A216 GR.WCB+13Cr	
4	Stem	1	ASTM A182 GR F6a	
5	Gasket	1	SS316+Graphite	
6	Bonnet	1	ASTM A216 GR.WCB	
7	Stud		ASTM A193 GR.B7M	
8	Nut		ASTM A194 GR.2HM	
9	Back Seat	1	ASTM A276 Type 410	
10	Packing	5	FE Graphite	
11	Gland	1	ASTM A276 Type 410	
12	Gland Flange	1	ASTM A216 GR.WCB	
13	Yoke	1	ASTM A216 GR.WCB	
14	Gear Operator	1	Carbon Steel	Groupware
15	Eye Bolt	2	ASTM A193 GR.B7M	
16	Eye Nut	2	ASTM A194 GR.2HM	
17	Pin	2	ASTM A29 Type 1025	
18	Nameplate	1	SS304	
19	Rivet	2	SS304	

Bosseal Valves

REV:	R0
P.O.NO:	

ITEM	SIZE	Ød	ØR	ØT	Ø0	n-Ød1	C	L	H	W	WT(Kg)
	16"	387	469.9	539.8	597	16-Ø29	36.6	406	1275	460	610
CAST STEEL GATE VALVE CLASS 150Lb/RF SIZE 16"								Bosseal Valve(Suzhou) Co., Ltd			
Marking System	MSS-SP-25	Inspection & Test : API 598									
Dim.of Flange	ASME B16.5	Shell Test(Hyd)		3.0 MPa							
Face To Face	ASME B16.10	Seat Test/Back Pressure(Hyd)		2.2 MPa		Draft	CDJ	11/17/2022			
Wall Thickness	API 600	Seat Test(Air)		0.6 MPa		Check	SJH	11/17/2022			
Overall	API 600, ASME B16.34, NACE MR0175						Appr	YYT	11/17/2022		