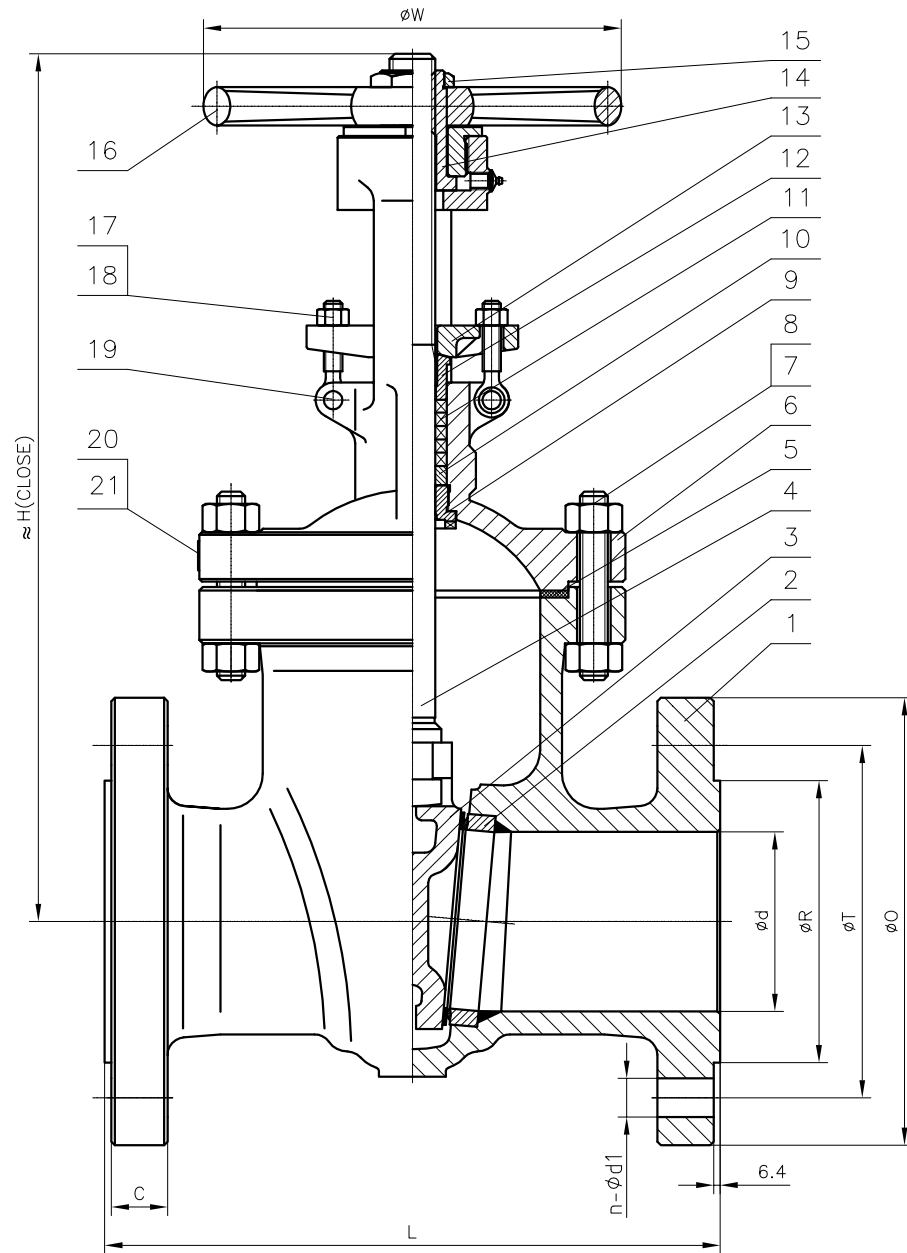

FIG.NO:



PARTS & MATERIAL LIST

ITEM	PART NAME	QTY	MATERIAL	NOTES
1	Body	1	ASTM A216 GR.WCB	
2	Seat Ring	2	ASTM A105N+STL#6	
3	Wedge	1	ASTM A216 GR.WCB+13Cr	WCB+STL
4	Stem	1	ASTM A182 GR F6a	
5	Gasket	1	SPW SS316+Graphite	
6	Bonnet	1	ASTM A216 GR.WCB	
7	Stud		ASTM A193 GR.B7M	
8	Nut		ASTM A194 GR.2HM	
9	Back Seat	1	ASTM A276 Type 410	
10	Spacer ring	1	ASTM A276 Type 410	
11	Packing	5	FE Graphite	
12	Gland	1	ASTM A276 Type 410	
13	Gland Flange	1	ASTM A216 GR.WCB	
14	Stem Nut	1	ASTM A439 GR.D-2	
15	Handwheel Nut	1	ASTM A29 Type 1025	
16	Handwheel	1	Ductile Iron	
17	Eye Bolt	2	ASTM A193 GR.B7M	
18	Eye Nut	2	ASTM A194 GR.2HM	
19	Pin	2	ASTM A29 Type 1025	
20	Nameplate	1	SS304	
21	Rivet	2	SS304	

**Bosseal** Valves

ITEM	SIZE	ød	øR	øT	øO	n-ød1	C	L	H(CLOSE)	W	WT(Kg)
	4"	102	157.2	215.9	273	8-ø26	38.1	432	530	300	130
	6"	152	215.9	292.1	356	12-ø29	47.8	559	705	450	250
CAST STEEL GATE VALVE CLASS 600Lb/RF SIZE 4"-6"									Bosseal Valve(Suzhou) Co., Ltd		
Marking System	MSS-SP-25	Inspection & Test : API 598									
Dim.of Flange	ASME B16.5	Shell Test(Hyd)		15.3 MPa							
Face To Face	ASME B16.10	Seat Test/Back Pressure(Hyd)		11.2 MPa	Draft	CDJ	11/17/2022				
Wall Thickness	API 600	Seat Test(Air)		0.6 MPa	Check	SJH	11/17/2022				
Overall	API 600, ASME B16.34, NACE MR0175				Appr	YYT	11/17/2022				

REV:	R0
PO.NO:	