

Class1500(RTJ)

NPS	DN	d	H	W	L	o	c	g	n-∅	b	y
4	100	92	603/720	450	549	310	241.5	194	8-35	54	161.93

NOTES:  
1. Pressure seal bonnet.

Performance Standard		
Nominal CL (PN)	1500LB	Test medium
Shell test pressure	39.0MPa	Water
Seal test pressure	28.6MPa	
Air test pressure	/MPa	Air
Suitable temperature	-29~425°C	
Suitable medium	Water/Steam/Oil etc	

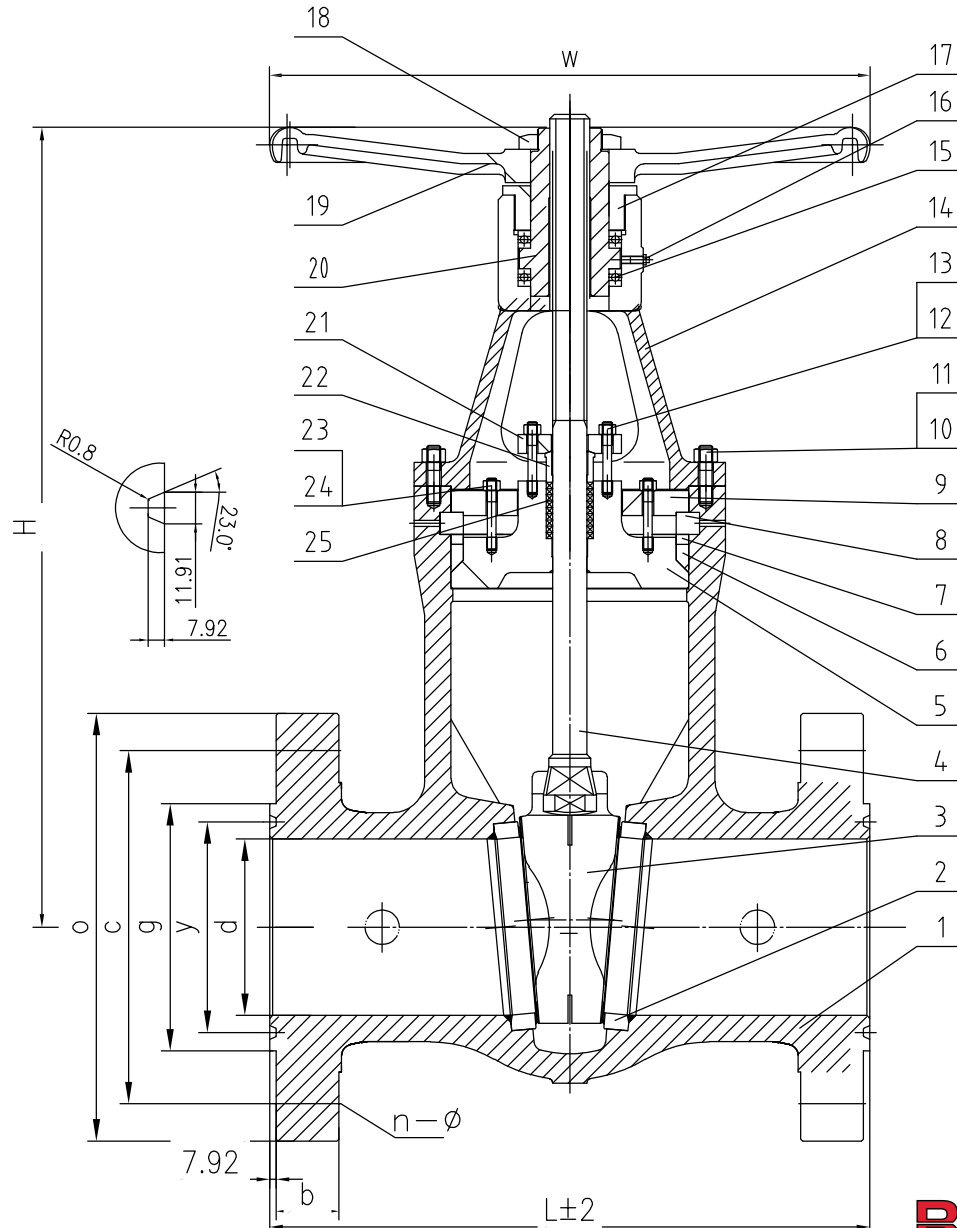

1	Body	A216 WCB	
2	Disc	A217 CA15+STL	
3	Seat	A182 F6A+STL	
4	Stem	A182 F6a	
5	Packing Box	A105	
6	Pressure Seat	Flexible Graphite+SS304	
7	Pressure Ring	SS304	
8	Four Ring	A105	
9	Supporting Cover	A105	
10	Bolt	A193 B7	
11	Nut	A194 2H	
12	Bolt	A193 B7	
13	Nut	A194 2H	
14	Yoke	A216 WCB	
15	Bearing	Alloy	
16	Lubricating Nipple	Brass	
17	Bearing Nut	1025	
18	Lock Nut	1025	
19	HandWheel	QT400-18	
20	Stem Nut	BRONZE	
21	GlandFlange	A216 WCB	
22	Gland	A182 F6a	
23	Bolt	A193 B7	
24	Nut	A194 2H	
25	Packing	Flexible Graphite+incomel wire	
NO.	PARTS NAME	MATERIAL	REMARK

GATE VALVE-PSB

Size	4"	Design&Manu	ASME B16.34
Class	1500Lb	Inspection&Test	API 598
Rev.	00	End Connection	ASME B16.5- RTJ
Man.Fig.		Face-to-face dimension	ASME B16.10

**Bosseal** Valves

Bosseal Valve(Suzhou) Co., Ltd