

Class300(RF)

NPS	DN	d	D	D1	D2	tf	n- $\phi$ d	L
2	50	50	165	127	92.1	20.7	8-19	216

PO ITEM: 21

VALVE CODE: VGASD023RECS70V

Performance Standard		
Nominal CL (PN)	300LB	Test medium
Shell test pressure	7.67MPa	Water
Seal test pressure	5.6MPa	
Air test pressure	0.6MPa	Air
Suitable temperature	-29~150°C	
Suitable medium	Water/Steam/Oil etc	

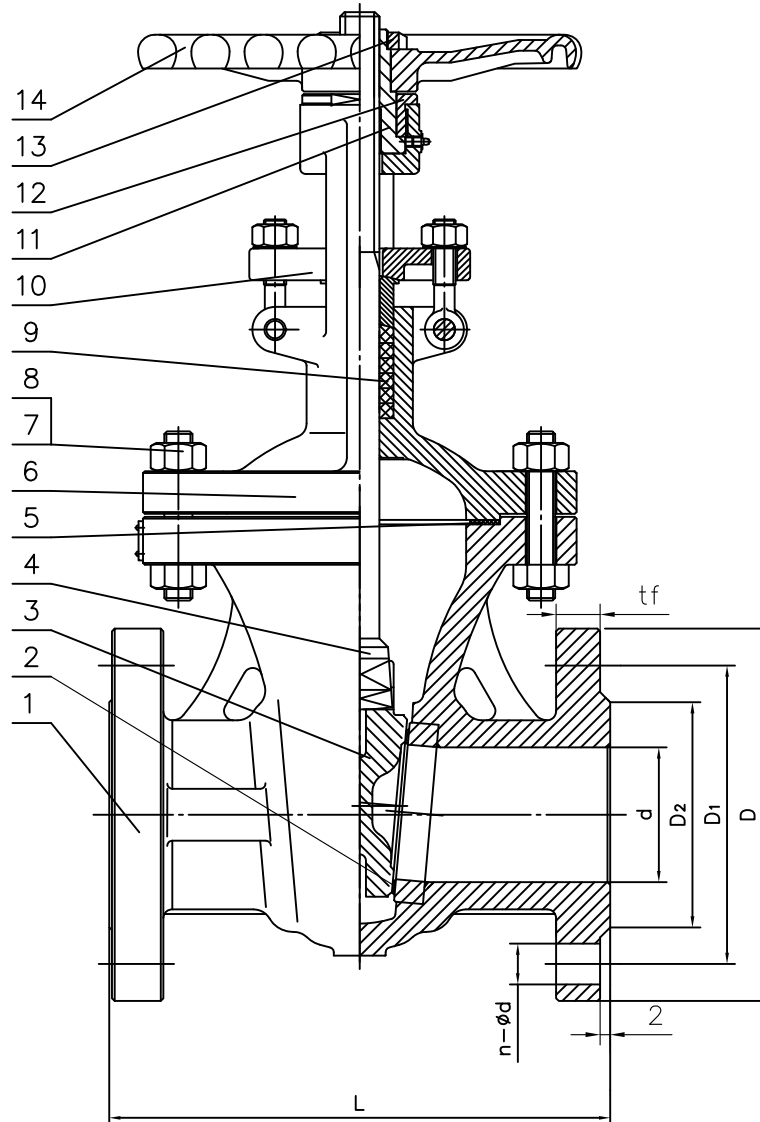

14	Hand Wheel	ASTM A536 60-40-18	
13	Lock Nut	ASTM A29 1035+Glavanized	
12	Nut Cap	ASTM A29 1035+Glavanized	
11	Stem Nut	Copper Alloy	
10	Gland Flange	ASTM A494 M35-1	
9	Stem Packing	PTFE	
8	Bonnet Nut	ASTM A194 8M	
7	Bonnet Bolt	ASTM A193 B8M	
6	Bonnet	ASTM A494 M35-1	
5	Winded Gasket	Graphite+SS304	
4	Stem	ASTM B564 N04400	
3	Flexible Wedge	ASTM A494 M35-1	
2	Seat Ring	ASTM B564 N04400	
1	Body	ASTM A494 M35-1	
NO.	PARTS NAME	MATERIAL	REMARK

GATE VALVE

Size	2"	Design&Manu	API 600
Class	300Lb	Inspection&Test	API 598
Rev.	00	End Connection	ASME B16.5 RF
Man.Fig.		Face-to-face dimension	ASME B16.10

**Bosseal** Valves

Bosseal Valve(Suzhou) Co., Ltd