

2000	2"	172	2"	51	330	150	=13.2 Kg
Psi	NPS	L	NPT	d	W	H	Unit Weight

Performance Standard		
Nominal CL (PN)	2000psi	Test medium
Shell test pressure	21.4MPa	Water
Seal test pressure	15.4MPa	
Air test pressure	0.6 MPa	Air
Suitable temperature	-29~150°C	
Suitable medium	Water/Steam/Oil etc	

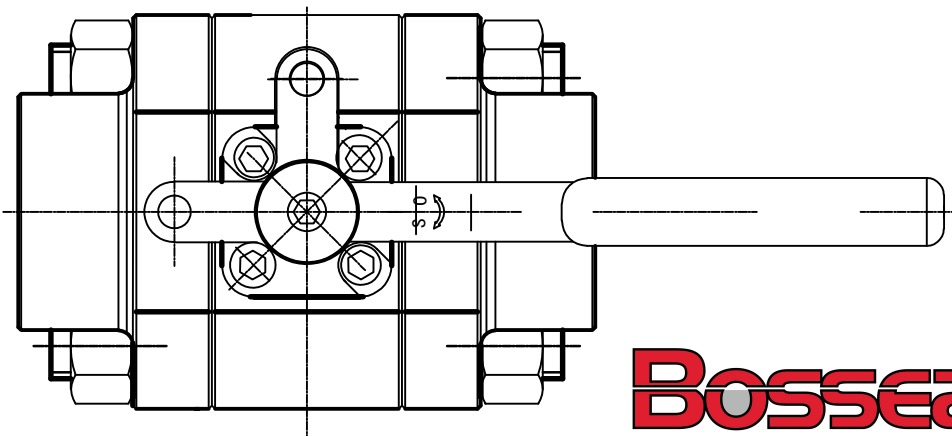
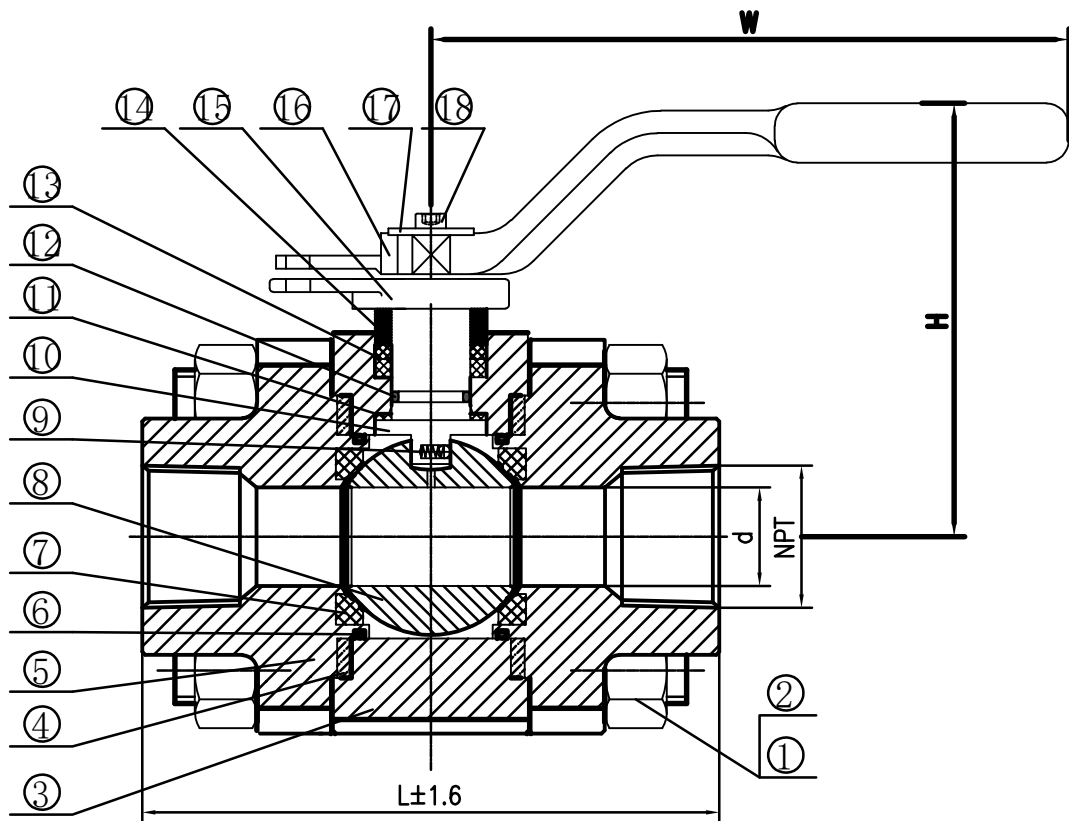

Technical Notes:

Temperature & pressure standards: ASME B16.34

Painting: PHOSPHATION, color in black.

18	Socket head bolts	SS	
17	Flat pad	C.S	
16	The handle	ASTM A216 WCB+Zn	
15	Gland Flange	ASTM A216 WCB+Zn	
14	Gland	ASTM A276 316	
13	Packing	Graphite	
12	O ring	VITON	
11	Thrust pad	RPTFE	
10	Stem	ASTM A182 F316	
9	Antistatic Spring	SS	
8	Ball	ASTM A182 F316	
7	Seat Ring	DEVLON	
6	O ring	VITON	
5	Bonnet	ASTM A350 LF2	
4	Gasket	SS +Graphite	
3	Body	ASTM A350 LF2	
2	Hex.Nut	ASTM A194 7	
1	Hex. Bolt	ASTM A320 L7	
NO.	PARTS NAME	MATERIAL	REMARK

Ball Valve 2000 Psi

Size	2"	Design&Manu	API 608
Class	2000PSI	Inspection&Test	API 598
Rev.	00	End Connection	ASME B1.20.1-FNPT
Man.Fig.		Face-to-face dimension	MFG'S

Bosseal Valve(Suzhou) Co., Ltd

Bosseal Valves