

Unit : mm

NPS	Dim	L	D	D1	D2	Z-φd	T	f	d	W	H	Weight/Kg
1/2"	x1"	165	125	98.4	73.0	4-φ16	15	2	25	265	110	9.4
2"	x1 1/2"	178	150	120.7	92.1	4-φ19	16.3	2	38	330	140	14

Performance Standard		
Nominal CL (PN)	150LB	Test medium
Shell test pressure	3.0MPa	Water
Seal test pressure	2.2MPa	
Air test pressure	0.6MPa	Air
Suitable temperature	-45~150℃	
Suitable medium	Water/Steam/Oil etc	

# Bosseal Valves

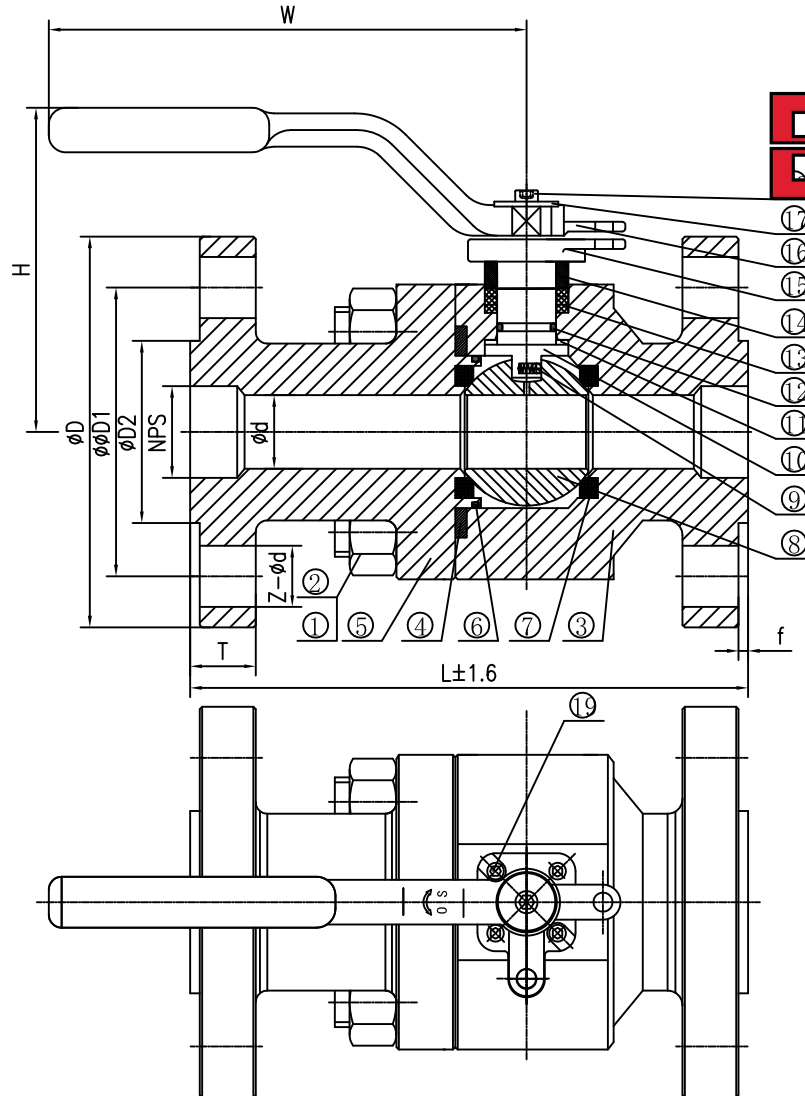

19	Socket head bolts	SS	
18	Socket head bolts	SS	
17	Flat pad	C.S	
16	The handle	ASTM A216 WCB	
15	Gland Flange	ASTM A352 LCB	
14	Gland	ASTM A276 316	
13	Packing	Graphite	
12	O ring	Viton GLT	
11	Thrust pad	RPTFE	
10	Stem	ASTM A182 F316	
9	Antistatic Spring	SS	
8	Ball	ASTM A182 F316	
7	Seat Ring	RPTFE	
6	O ring	Viton GLT	
5	Bonnet	ASTM A350 LF2	
4	Gasket	SS316+Graphite	
3	Body	ASTM A350 LF2	
2	Hex.Nut	ASTM A194 7L	
1	Hex. Bolt	ASTM A320 L7	
NO.	PARTS NAME	MATERIAL	REMARK

### Floating Ball Valve

Size	1.5, 2"	Design&Manu	ISO 17292
Class	150Lb	Inspection&Test	API 598
Rev.	00	End Connection	ASME B16.5
Man.Fig.		Face-to-face dimension	ASME B16.10

Bosseal Valve(Suzhou) Co., Ltd

Item No.	TAG No.	Spec
12	V94069	VBA1202
13	V94075	