

800	1"x3/4"	128	1"	33.9	13	19	265	110	4.64
800	3/4"x1/2"	113	3/4"	27.2	13	13	210	95	2.3
CLASS	NPS	L	NPS	E	L1	d	W	H	Weight/kg

Performance Standard		
Nominal CL (PN)	800LB	Test medium
Shell test pressure	21.4MPa	Water
Seal test pressure	15.4MPa	
Air test pressure	0.6MPa	Air
Suitable temperature	-45~150℃	
Suitable medium	Water/Steam/Oil etc	

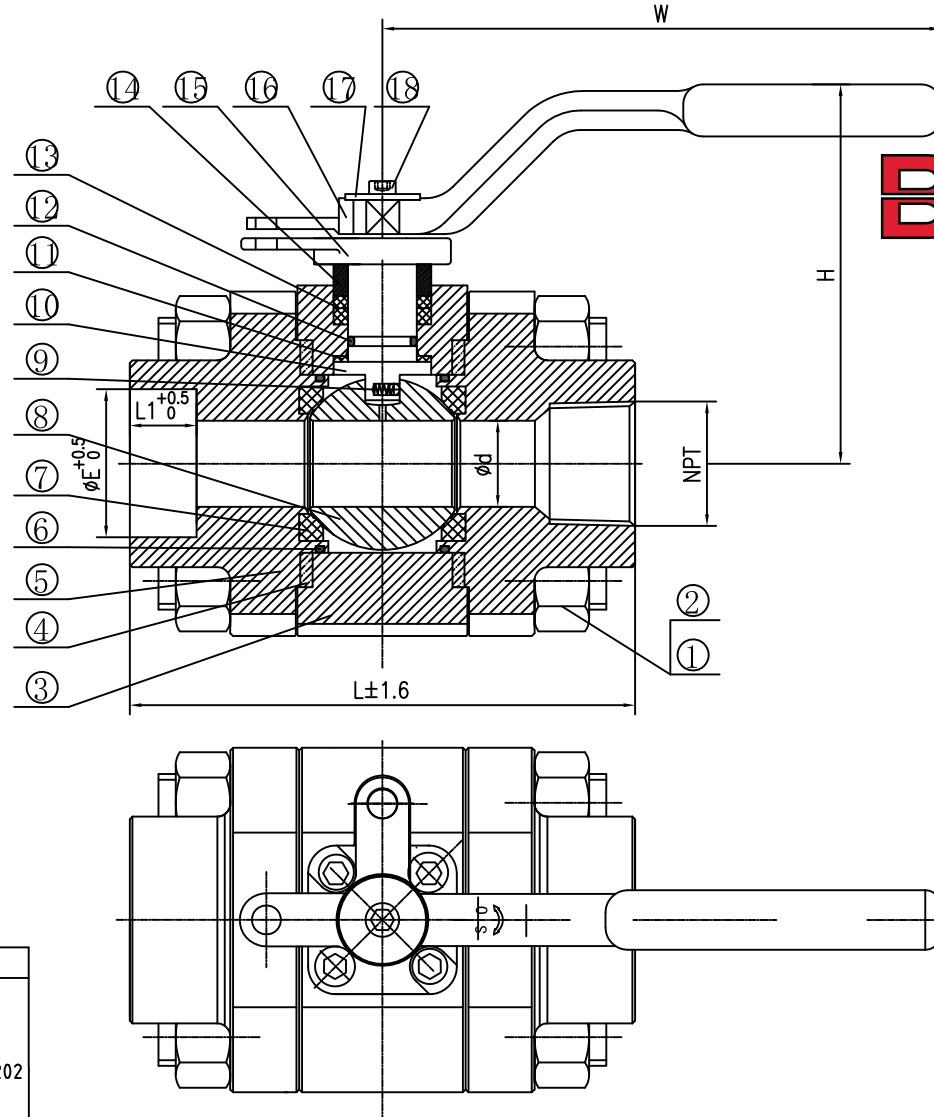

Bosseal Valves

18	Socket head bolts	SS	
17	Flat pad	C.S	
16	The handle	ASTM A216 WCB	
15	Gland Flange	ASTM A352 LCB	
14	Gland	ASTM A276 316	
13	Packing	Graphite	
12	O ring	Viton GLT AED	
11	Thrust pad	RPTFE	
10	Stem	17-4PH	
9	Antistatic Spring	SS	
8	Ball	ASTM A182 F316	
7	Seat Ring	PEEK	
6	O ring	Viton GLT AED	
5	Bonnet	ASTM A350 LF2	
4	Gasket	SS316+Graphite	
3	Body	ASTM A350 LF2	
2	Hex.Nut	ASTM A194 7L	
1	Hex. Bolt	ASTM A320 L7	
NO.	PARTS NAME	MATERIAL	REMARK

Floating Ball Valve

Size	0.75,1"	Design&Manu	API 608
Class	800Lb	Inspection&Test	API 598
Rev.	00	End Connection	ASME B1.20.1&ASME B16.11
Man.Fig.		Face-to-face dimension	MFG'S

Bosseal Valve(Suzhou) Co., Ltd

Item No.	TAG No.	Spec
21	V94.071	VBA8202
22	V94.125	
	V9XXXH	
	V9XXXJ	
	V9XXAC	
	V9XXAD	
	V9XXAE	