

VALVE SIZE	DIMENSION IN mm.									Weight	Item
	A	B	C	D(Min)	E	f	H	L	n-ØF		
4"-150LB	230	22.3	157.2	100	190.5	2	450	460	8-Ø19	≈140kg	3

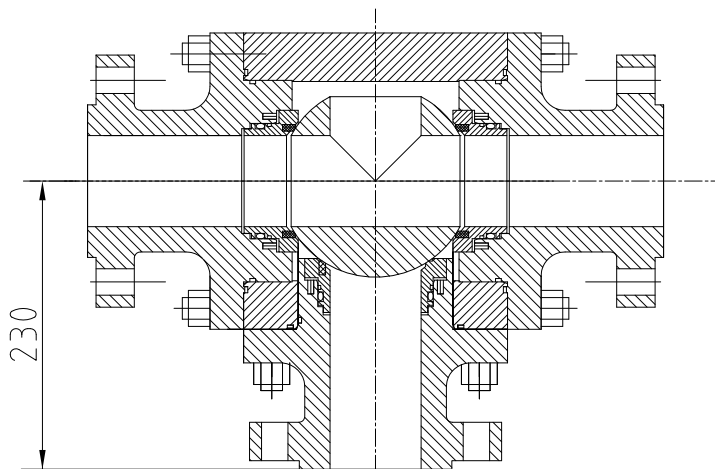
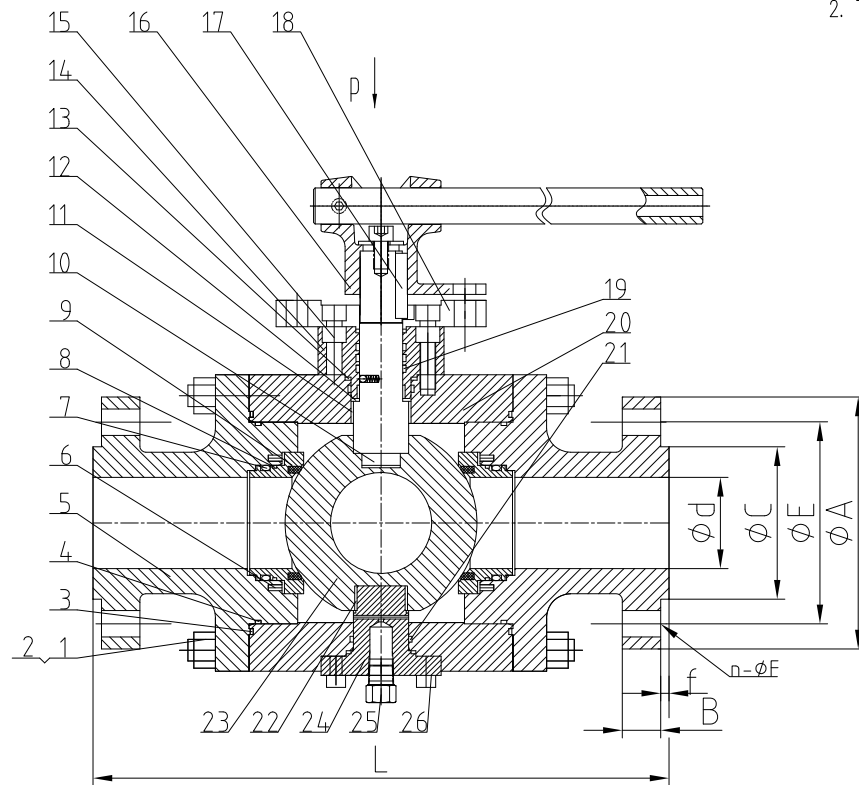

NOTES:

1. The fire safe is designed in accordance with API 607.
2. Test duration per API 6D.

Performance Standard		
Nominal CL (PN)	150LB	Test medium
Shell test pressure	3.0MPa	Water
Seal test pressure	2.1Mpa	
Air test pressure	0.6Mpa	Air
Suitable temperature	-29~120°C	
Suitable medium	Water/Gas/Oil etc	

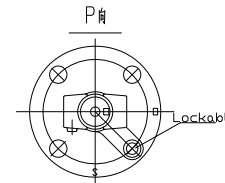

ANTISTATIC DEVICE

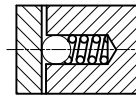

T PORT

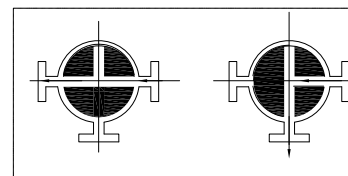

1	Body stud	ASTM A193 - B8M	
2	Body nut	ASTM A194 - 8M	
3	Body gasket	SS316+Graphite	
4	O-ring	Viton-AED	
5	Bonnet	ASTM A182 F316	
6	Spring	INCONEL X-750	
7	O-ring	Viton-AED	
8	Gasket	Graphite	
9	Seat	ASTM A182 F316+RPTFE	
10	Stem	ASTM A182 F316	
11	Thrust bearing	316+PTFE	
12	Thrust Gasket	PTFE	
13	Gasket	Graphite	
14	Packing box	ASTM A182 F316	
15	Screw	ASTM A193 B8M	
16	LEVER	CS+ZN	
17	Key	SS316	
18	Top Flange	ASTM A182 F316	
19	O-ring	Viton-AED	
20	Body	ASTM A182 F316	
21	O-ring	Viton-AED	
22	Thrust bearing	SS+PTFE	
23	Ball	ASTM A182 F316	
24	Shaft	ASTM A182 F316	
25	Plug	SS316	
26	Gasket	Graphite	
NO.	PARTS NAME	MATERIAL	REMARK

3 Way Trunnion Ball Valve (T Port)

Size	4"	Design&Manu	API 6D
Class	150Lb	Inspection&Test	API 598
Rev.	00	End Connection	ASME B16.5-RF
Man.Fig.		Face-to-face dimension	Manufacturer standard

Bosseal Valves

Bosseal Valve(Suzhou) Co., Ltd