

Model:WD495C/S-I

400V|50Hz|3Phase|Pf.:0.8

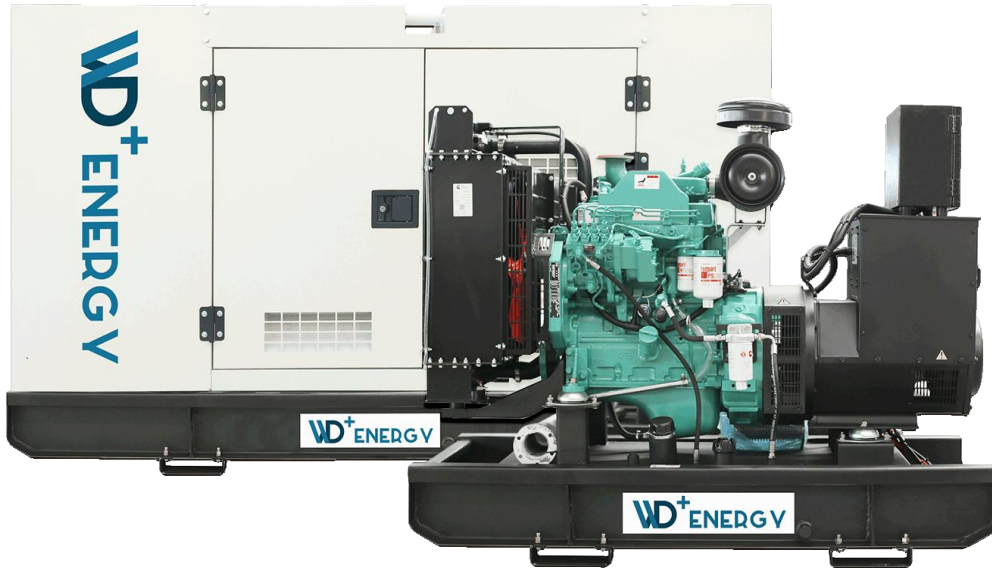

GENERATOR SPECIFICATION

ESP ⁽¹⁾ Standby Power	495 kVA 396 kW	PRP ⁽²⁾ Prime Power	450 kVA 360 kW
Engine	DCEC QSZ13-G2	Alternator	WD ⁺ WD354C

Power Definition

(1) ESP (Standby Power):

The standby power rating is applicable for supplying emergency power in variable load applications in accordance with ISO 8528-1. Overload is not allowed

(2) PRP (Prime Power):

Prime Power is available for an unlimited number of annual operating hours in variable load applications, in accordance with ISO 8528-1.

Standard Reference Condition

Note: Standard reference condition 25°C[77°F] air inlet temp, 1000m(328ft) A.S.L 30% relative humidity. Fuel consumption data with diesel fuel with specific gravity of 0.85 and conforming to BS 2869: 1998, Class A2

GENERAL FEATURES

Dimension		Open	Silent
Length(L)	mm	3250	4050
Width(W)	mm	1400	1700
Height(H)	mm	2100	2230
New Weight	kg	3175	4500
Fuel Tank	L	≤700	≤750

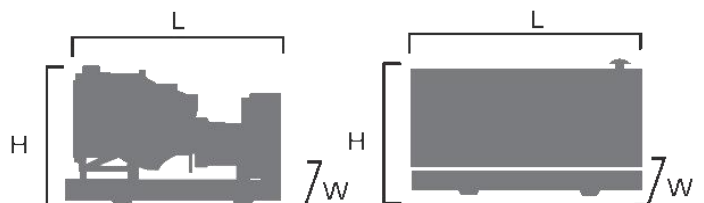

Model:WD495C/S-I

400V|50Hz|3Phase|Pf.:0.8

GENERATOR RATINGS

Voltage	Hz	Phase	PF	Standby	Standby Ratings		Prime Ratings	
			COS Φ	Amps	kVA	kW	kVA	kW
440 /254	50	3	0.8	649.5	495	396	450	360
415 /240	50	3	0.8	688.7	495	396	450	360
400 /230	50	3	0.8	714.5	495	396	450	360
380 /220	50	3	0.8	752.1	495	396	450	360

Also available in the following voltages: 415/240V-380/220V-220/127V-200/115V; or other optional voltage please refer to rating table.

ENGINE SPECIFICATION

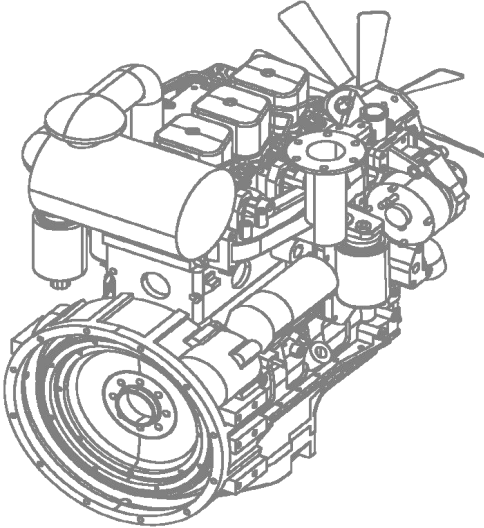
General Engine Data					
Manufacturer	Cummins				
Engine Model	QSZ13-G2				
Structure Type	6 Cylinder,4-Stroke, In-line,Water-cooled, Direct Injection				
BorexStroke	130x163 mm				
Displacement	13.0L				
Compression ratio	17.0:1				
Standby Power	415kW/557hp				
Prime Power	390kW/523hp				
Rated Rotation Speed	1500 RPM				
Aspiration	Turbo&Charge Air Cooled				
Speed Control Tye	Electronic			Fuel Consumption	
Coolant Capacity- Engine Only	23.1L			Consumption @100% load ESP	95.8 L/H
Lubricating System	Pressure Splashed			Consumption @100% load PRP	89.1 L/H
Lubricant Grade	Above CD or SAE 10W-30、 15W-40			Consumption @75% load PRP	65.1 L/H
Lubricant Capacity	45.42L	Consumption @50% load PRP	43.2 L/H		
Starter System	24V Electric System	Consumption @50% load PRP	23.6 L/H		
Cranking Motor Capacity	24V	Engine Options			
Charging Generator Capacity	28V 40A	<input type="checkbox"/> Water Jacked Heater			
Fuel Grade	0# (Summer), -10# (Winter), -35#(Cold)	<input type="checkbox"/> Radiator Water Level Sensor			
		<input type="checkbox"/> Oil Heater			
		<input type="checkbox"/> Heavy Duty Air Filter			

Model:WD495C/S-I

400V|50Hz|3Phase|Pf.:0.8

ALTERNATOR SPECIFICATION

General Alternator Data	
Manufacturer	WD ⁺
Alternator Model	WD354C
Standby Output	396kW/494kVA
Prime Output	360kW/450kVA
Number of phase	3
Power factor (Cos Φ)	0.8
Poles	4
Winding Connections(Standard)	Star-serie
Terminals	12
Insulation type	H class
Winding Pitch	2/3
IP rating	IP23
Altitude	≤1000m
Excitation system	Self-excited
Bearing	Single bearing
Voltage regulator	A.V.R
Couping	Flexible disc
Voltage Regulation,Steady State	±1%
Telephone Influence Factor	< 50
Sudden Voltage Warp (100% Sudden Reduce)	±1%
Sudden Voltage Warp(Sudden Increase)	±25%
Voltage Stable Time (100% Sudden Reduce)	≤6S
Voltage Stable Time (Sudden Increase)	≤6S
Frequency Reduce	0-5% adjustable
Frequency Regulation,Stead State	≤1.5%
Frequency Waving	≤0.8%
Sudden Frequency Warp (100% Sudden Reduce)	≤+12%

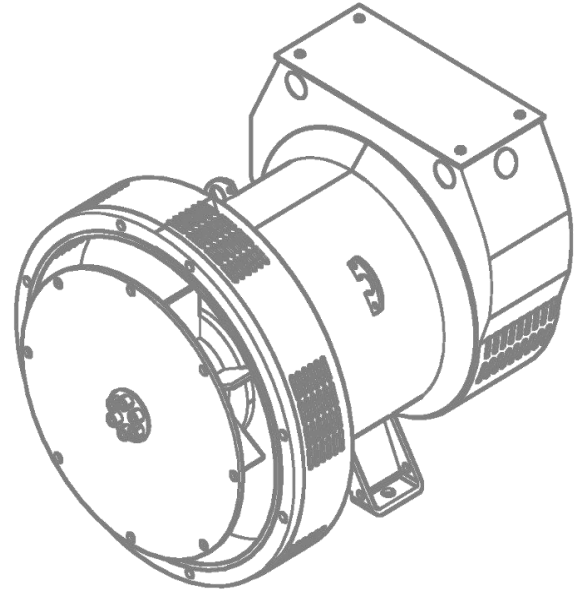

General Alternator Data	
Sudden Frequency Warp(100% Sudden Increase)	≤-10%
Frequency Recovery Time (100% Sudden Reduce)	≤5S
Frequency Recovery Time (Sudden Increase)	≤5S
Alternator Options	
○ Winding Temp Measuring Instrument	
○ Alternator Pre-heater	
○ PMG	
○ Anti-damp and Anti-corrosion Treatment	
○ Anti-condensation Heater	
○ Winding and bearing RTD	

CONTROLLER SPECIFICATION

Function		WD ⁺ PLC1.0		WD ⁺ PLC2.0		WD ⁺ PLC3.0	
		HGM 6110N	HGM 6120N	DSE7310 MKII	DSE7320 MKII	DSE8610 MKII	DSE8620 MKII
		Standard	Option	Standard	Option	Standard	Option
Manufacturer		SMARTGEN		DEEPSEA			
AMF		×	●	×	●	Auto Start	●
ECU		○	○	●	●	●	●
Communication Port		USB		RS232/485/USB		RS232/485/USB/ Ethernet	
Monitor Function	Generator Set Voltage	●	●	●	●	●	●
	Generator Set Current	●	●	●	●	●	●
	Generator Set Frequency	●	●	●	●	●	●
	Generator Set Speed	●	●	●	●	●	●
	Generator Set Output Power	●	●	●	●	●	●
	Generator Set Power Factor	●	●	●	●	●	●
	Generator Set Run Hours	●	●	●	●	●	●
	Oil Pressure	●	●	●	●	●	●
	Water Temperature	●	●	●	●	●	●
	Battery Voltage	●	●	●	●	●	●
	Fuel Level	●	●	●	●	●	●
	Mains Voltage	×	●	×	●	●	●
	Mains Frequency	×	●	×	●	●	●
	Mains Current	×	●	×	●	●	●
	Synchronising	×	×	×	×	●	●
	Mains Parallel Operation	×	×	×	×	●	●
Protection	Low Oil Pressure	●	●	●	●	●	●
	Water Temperature High	●	●	●	●	●	●
	Over Speed	●	●	●	●	●	●
	Battery Charge Failure	●	●	●	●	●	●
	Reverse Power	×	×	×	×	●	●
Application		×	AMF+ATS	×	AMF+ATS	Multiple Island or Single Parallel to Mains	Single Parallel to Mains

● Standard ○ Optional × Impossible

STANDARD FEATURES	GENERATOR SET OPTIONS
● Standard Auto Control System WD+ PLC1.0	<input type="checkbox"/> Tools Box
● Emergency Stop Button	<input type="checkbox"/> Extended Range Daily Fuel Tank
● Exhaust System (Including Muffler)	<input type="checkbox"/> Spare Parts
● Operation and Maintenance Manual	
● Oil Drain Valve	
● Starting Batteries (Maintenance-free with Connective Wires)	CONTROL SYSTEM OPTIONS
● Special Tools	<input type="checkbox"/> Remote Control System
● Base Fuel Tank	<input type="checkbox"/> Battery Charger
● MCCB	<input type="checkbox"/> Automatic Transfer Switch
	<input type="checkbox"/> Synchronizing System
	<input type="checkbox"/> Adjustable Ear th Leakage Relay

FUE SYSTEM OPTIONS
<input type="checkbox"/> Fuel-Water Separator
<input type="checkbox"/> Low Fuel Level Alarm
<input type="checkbox"/> Automatic Fuel Feeding System
<input type="checkbox"/> Fuel T-valves

CANOPY OPTIONS
<input type="checkbox"/> Rental Type Canopy
<input type="checkbox"/> Containerized Canopy
<input type="checkbox"/> Telecom Base Canopy
<input type="checkbox"/> Trailer

LUB OIL SYSTEM OPTIONS
<input type="checkbox"/> Oil Pre-heater
<input type="checkbox"/> Oil Tempuratuere Sensor
<input type="checkbox"/> Oil Drain Pump

DISTRIBUTED BY



info@hiwedoplus.com | www.hiwedoplus.com

This document is not contractual. The WD+ reserves the right to modify any of the characteristics stated in this document without notice, in a constant effort to improve the quality of its products.