

Dimensions of Class 150 Blind and Spacer

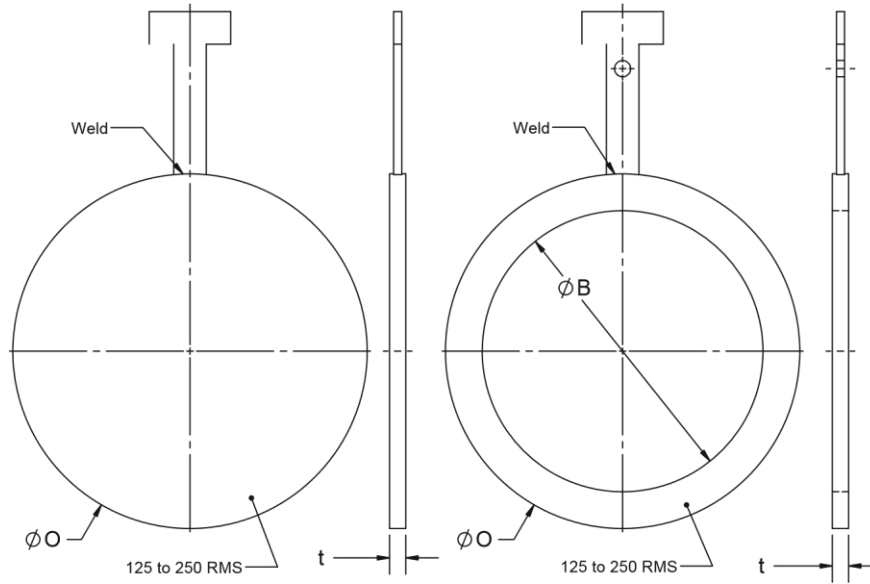

ASME B16.48 BLINDS AND SPACERS

NPS	Inside Diameter B		Outside Diameter O		Thk t		Blid Wgt	Spr Wgt
	In.	mm.	In.	mm.	In.	mm.		
1/2	0.62	16	1.75	44	0.12	3	0.2	0.1
3/4	0.82	21	2.12	54	0.12	3	0.2	0.1
1	1.05	27	2.50	64	0.12	3	0.2	0.1
1 1/4	1.66	42	2.88	73	0.25	6	0.5	0.2
1 1/2	1.90	48	3.25	83	0.25	6	0.6	0.3
2	2.38	60	4.00	102	0.25	6	0.6	0.3
2 1/2	2.88	73	4.75	121	0.25	6	1.2	0.6
3	3.50	89	5.25	133	0.25	6	1.8	0.9
3 1/2	4.00	102	6.25	159	0.38	10	2.2	1.1
4	4.50	114	6.75	171	0.38	10	2.6	1.3
5	5.56	141	7.62	194	0.38	10	4.4	2.2
6	6.62	168	8.62	219	0.50	13	6.2	3.1
8	8.62	219	10.88	276	0.50	13	12.7	6.4
10	10.75	273	13.25	337	0.62	16	21.1	10.6
12	12.75	324	16.00	406	0.75	19	37.3	18.6
14	14.00	356	17.62	448	0.75	19	52.6	26.3
16	16.00	406	20.12	511	0.88	22	76.6	38.3
18	18.00	457	21.50	546	1.00	25	92	46
20	20.00	508	23.75	603	1.12	28	118	59
24	24.00	610	28.12	714	1.25	32	203	102

Dimensions of Class 300 Blind and Spacer

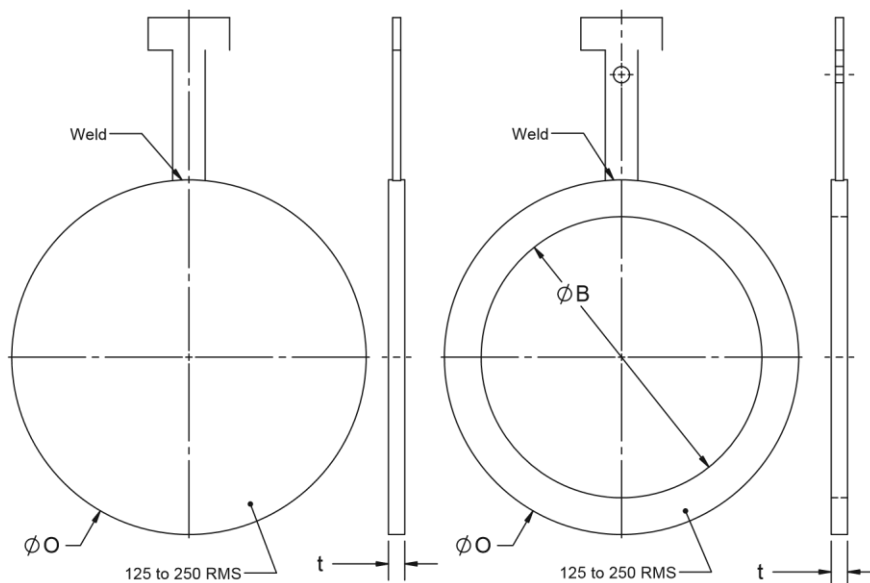

ASME B16.48 BLINDS AND SPACERS

NPS	Inside Diameter B		Outside Diameter O		Thk t		Bl'd Wgt	Spr Wgt
	In.	mm.	In.	mm.	In.	mm.		
1/2	0.62	16	2.00	51	0.25	6	0.33	0.17
3/4	0.82	21	2.50	64	0.25	6	0.33	0.17
1	1.05	27	2.75	70	0.25	6	0.33	0.17
1 1/4	1.66	42	3.12	79	0.25	6	0.6	0.3
1 1/2	1.90	48	3.62	92	0.25	6	0.87	0.43
2	2.38	60	4.25	108	0.38	10	1.2	0.6
2 1/2	2.88	73	5.00	127	0.38	10	1.6	0.8
3	3.50	89	5.75	146	0.38	10	1.93	0.97
3 1/2	4.00	102	6.38	162	0.50	13	3.6	1.8
4	4.50	114	7.00	178	0.50	13	5.19	2.6
5	5.56	141	8.38	213	0.62	16	9.32	4.66
6	6.62	168	9.75	248	0.62	16	13.39	6.69
8	8.62	219	12.00	305	0.88	22	26.64	13.32
10	10.75	273	14.12	359	1.00	25	43.29	21.65
12	12.75	324	16.50	419	1.12	28	68.6	34.3
14	14.00	356	19.00	483	1.25	32	101.9	50.95
16	16.00	406	21.12	537	1.50	38	143.2	71.6
18	18.00	457	23.38	594	1.62	41	196.5	98.24
20	20.00	508	25.62	651	1.75	44	249	124.5
24	24.00	610	30.38	772	2.00	51	416.3	208.1

Dimensions of Class 600 Blind and Spacer

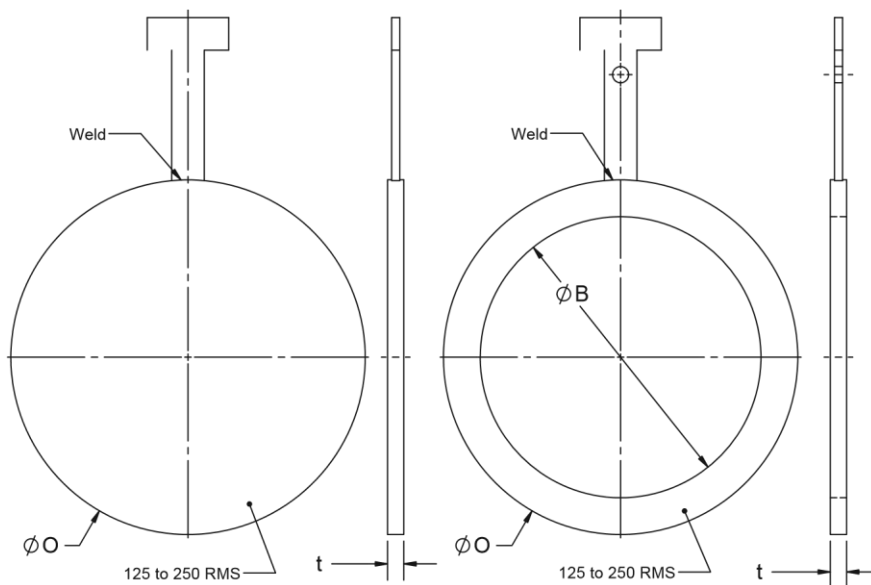

ASME B16.48 BLINDS AND SPACERS

NPS	Inside Diameter B		Outside Diameter O		Thk t		Bld Wgt	Spr Wgt
	In.	mm.	In.	mm.	In.	mm.		
1/2	0.62	16	2.00	51	0.25	6	0.33	0.165
3/4	0.82	21	2.50	64	0.25	6	0.33	0.17
1	1.05	27	2.75	70	0.25	6	0.53	0.27
1 1/4	1.44	37	3.12	79	0.38	10	0.73	0.37
1 1/2	1.68	43	3.62	92	0.38	10	0.87	0.43
2	2.16	55	4.25	108	0.38	10	1.47	0.73
2 1/2	2.64	67	5.00	127	0.50	13	2.6	1.3
3	3.26	83	5.75	146	0.50	13	3.66	1.83
3 1/2	3.76	96	6.25	159	0.62	16	5.86	2.93
4	4.26	108	7.50	191	0.62	16	7.99	4
5	5.30	135	9.38	238	0.75	19	15.65	7.83
6	6.36	162	10.38	264	0.88	22	23.31	11.66
8	8.33	212	12.50	318	1.12	28	39.96	19.98
10	10.42	265	15.62	397	1.38	35	78.26	39.13
12	12.39	315	17.88	454	1.62	41	123.2	61.61
14	13.62	346	19.25	489	1.75	44	153.2	76.59
16	15.62	397	22.12	562	2.00	51	226.4	113.2
18	17.62	448	24.00	610	2.12	54	299.7	149.9
20	19.56	497	26.75	679	2.50	64	412.9	206.5
24	23.50	597	31.00	787	2.88	73	649.4	324.7

Dimensions of Class 900 Blind and Spacer

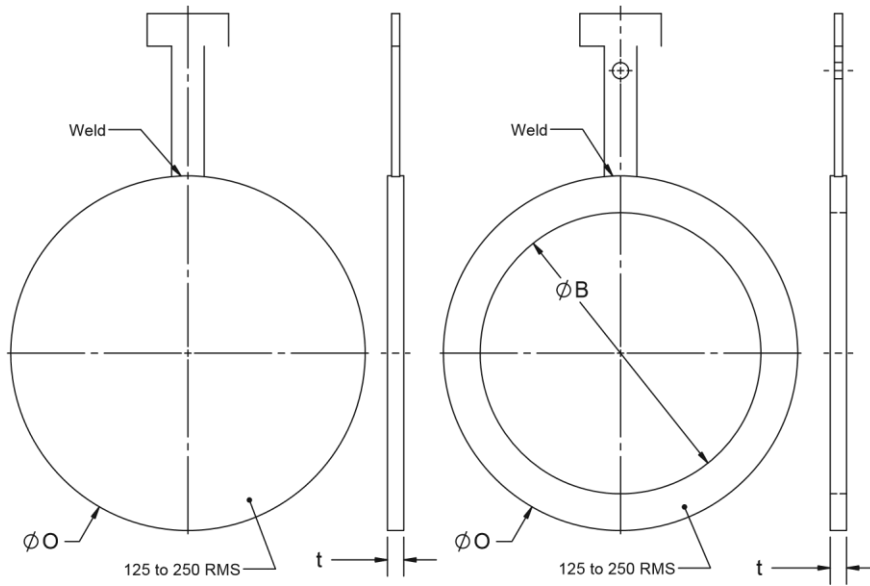

ASME B16.48 BLINDS AND SPACERS

NPS	Inside Diameter B		Outside Diameter O		Thk t		Bld Wgt	Spr Wgt
	In.	mm.	In.	mm.	In.	mm.		
1/2	0.62	16	2.38	60	0.25	6	0.33	0.17
3/4	0.82	21	2.62	67	0.25	6	0.33	0.17
1	1.05	27	3.00	76	0.25	6	0.6	0.3
1 1/4	1.44	35	3.38	86	0.38	10	0.93	0.47
1 1/2	1.68	41	3.75	95	0.38	10	1.2	0.6
2	2.16	53	5.50	140	0.50	13	3.13	1.57
2 1/2	2.64	63	6.38	162	0.50	13	4.73	2.36
3	3.26	78	6.50	165	0.62	16	6.33	3.16
4	4.26	102	8.00	203	0.75	19	11.32	5.66
5	5.30	128	9.62	244	0.88	22	23.18	11.59
6	6.36	154	11.25	286	1.00	25	34.97	17.48
8	8.33	203	14.00	356	1.38	35	64.6	32.3
10	10.42	255	17.00	432	1.62	41	118.6	59.27
12	12.39	303	19.50	495	1.88	48	186.5	93.24
14	13.62	333	20.38	518	2.12	54	203.1	101.6
16	15.62	381	22.50	572	2.38	60	273.1	136.5
18	17.62	429	25.00	635	2.62	67	379	189.8
20	19.56	478	27.38	695	2.88	73	499.5	249.8
24	23.50	575	32.88	835	3.50	89	832.5	416.3

Dimensions of Class 1500 Blind and Spacer

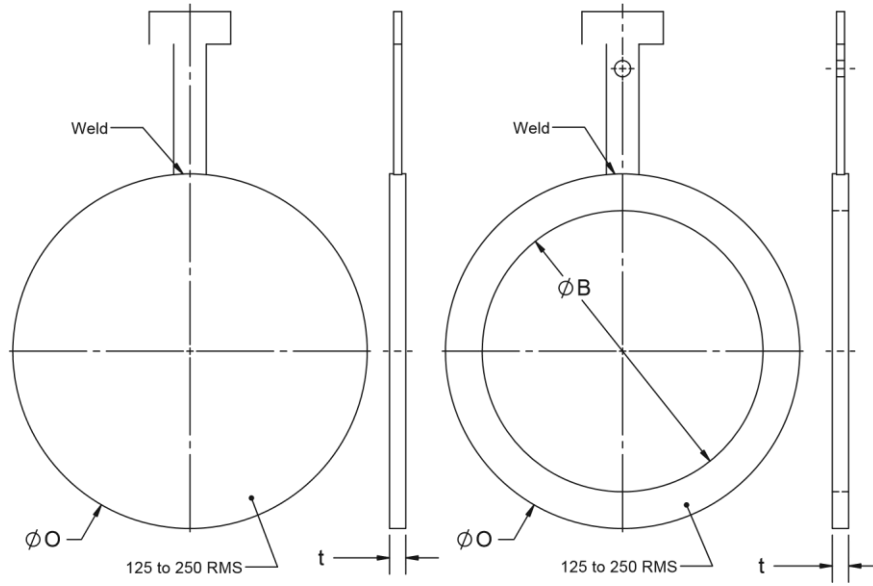

ASME B16.48 BLINDS AND SPACERS

NPS	Inside Diameter B		Outside Diameter O		Thk t		Bld Wgt	Spr Wgt
	In.	mm.	In.	mm.	In.	mm.		
1/2	0.62	16	2.38	60	0.25	6	0.4	0.2
3/4	0.82	21	2.62	67	0.38	10	0.73	0.37
1	1.05	27	3.00	76	0.38	10	0.93	0.47
1 1/4	1.38	37	3.38	86	0.38	10	1.2	0.6
1 1/2	1.61	43	3.75	95	0.50	13	1.86	0.93
2	2.07	55	5.50	140	0.50	13	4.2	2.1
2 1/2	2.47	67	6.38	162	0.62	16	6.93	3.46
3	3.07	83	6.75	171	0.75	19	9.32	4.66
4	4.03	108	8.12	206	0.88	22	14.65	7.33
5	5.05	135	9.88	251	1.12	28	27.97	13.99
6	6.06	162	11.00	279	1.38	35	41.96	20.98
8	7.98	212	13.75	349	1.62	41	75.26	37.63
10	10.02	265	17.00	432	2.00	51	141.9	70.93
12	11.94	315	20.38	518	2.38	60	176.5	88.25
14	13.12	346	22.62	575	2.62	67	331	165.5
16	15.00	397	25.12	638	3.00	76	461.5	230.8
18	16.88	448	27.62	702	3.38	86	622	311
20	18.81	497	29.62	752	3.75	95	779.2	389.6
24	22.62	597	35.38	899	4.38	111	1030	515.2

Dimensions of Class 2500 Blind and Spacer

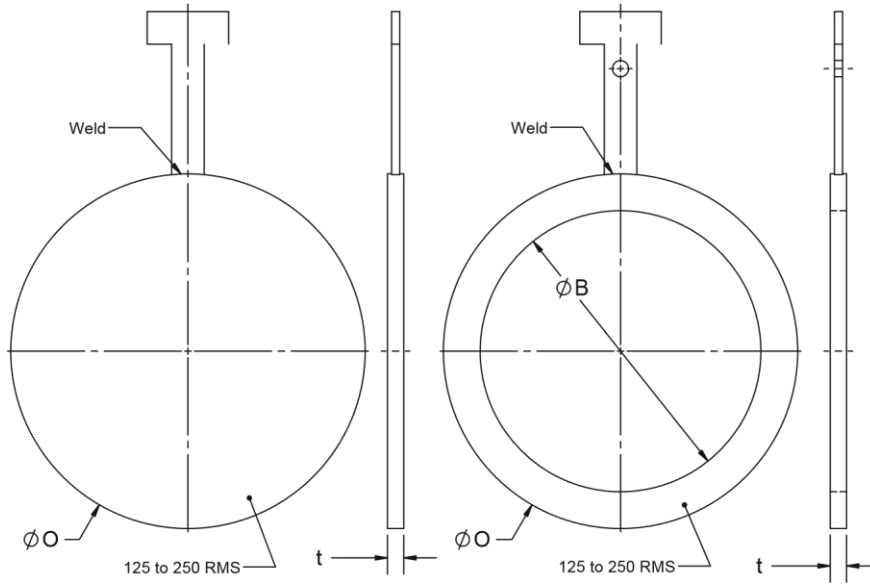

ASME B16.48 BLINDS AND SPACERS

NPS	Inside Diameter B		Outside Diameter O		Thk t		Bld Wgt	Spr Wgt
	In.	mm.	In.	mm.	In.	mm.		
1/2	0.62	16	2.62	67	0.38	10	0.73	0.37
3/4	0.82	21	2.88	73	0.38	10	0.87	0.43
1	1.05	27	3.25	83	0.38	10	1.13	0.57
1 1/4	1.38	35	4.00	102	0.50	13	2.26	1.13
1 1/2	1.61	41	4.50	114	0.62	16	3.46	1.73
2	2.07	53	5.62	143	0.62	16	5.39	2.7
2 1/2	2.47	63	6.50	165	0.75	19	8.72	4.36
3	3.07	78	7.62	194	0.88	22	13.99	6.99
4	4.03	102	9.12	232	1.12	28	24.64	12.32
5	5.05	128	10.88	276	1.38	35	43.29	21.65
6	6.06	154	12.38	314	1.62	41	64.6	32.3
8	7.81	198	15.12	384	2.12	54	124.5	62.27
10	9.75	248	18.62	473	2.62	67	232.4	116.2