

USER'S MANUAL

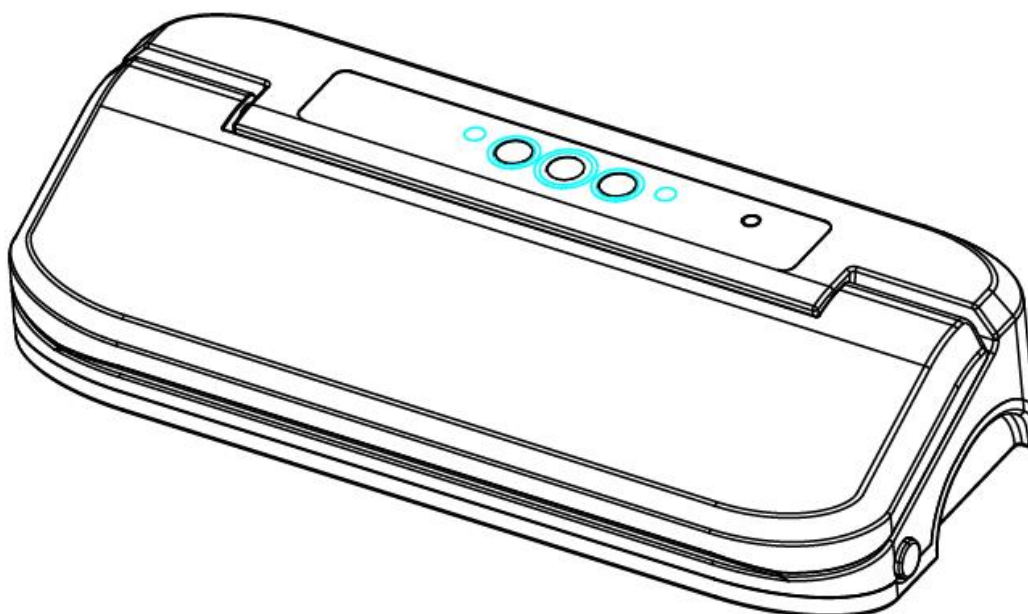

Vacuum Sealer VS150

220-240V~50Hz

160W

Important Points for your Safety

Read and fully understand all instructions and warnings prior to using this machine. Your safety is most important!

1. Read the instructions carefully.
2. Do not allow the appliance to be used as a toy.
3. This appliance should not be operated by children.
4. Do not operate the appliance with a damaged power cord or plug.
5. Do not use the appliance on a wet or hot surface, or near a heat source.
6. Always use the appliance on a level surface.
7. Do not immerse any part of the appliance, power cord or plug into water or other liquid.
8. To disconnect, unplug the power cord from the electrical outlet. Do not disconnect by pulling on the cord. Always unplug the appliance before cleaning and when not in use.
9. Do not operate the appliance if it malfunctions or is any way damaged. If the cord or the machine is damaged, please return it to our after-sales department for proper service, replacement or repair.
10. Close supervision is required when this product is used near children.
11. The appliance is not for commercial use. If sealing more than 20 bags continuously, wait at least 25 minutes before resuming use of your appliance.
12. Keep the upper lid of the appliance unlocked when not in use.

This appliance is for HOUSEHOLD USE ONLY.

Do not attempt to service this product. Service should be performed by an authorized service representative.

A short power-supply cord is provided to reduce the risk resulting from becoming entangled in or tripping over a longer cord. Extension cords are not prohibited from being used when care is exercised in their use. When an extension cord is used the marked electrical rating of the extension cord shall be no less than the marked electrical rating of the appliance. The longer cord shall be arranged so that it does not drape over the counter-top or tabletop where it is capable of being tripped over, snagged, or pulled on unintentionally, especially by children.

Start Enjoying the Benefits of your Vacuum Sealer System

Thank you for purchasing this vacuum sealer.

With this new vacuum sealer, just close the lid by pressing down on both sides. When the lid is locked in place, press the vacuum button and let the vacuum sealer do the rest! The

machine will continue to vacuum out air and then seal the bag; release the lid by pressing the buttons on both sides of the machine and your items are now vacuum fresh!

Your new vacuum sealer system includes the following :

- VS150 Vacuum Sealer
- English User Manual
- Starter Bags (optional)
- Accessory Hose (optional)

Vacuum Sealing Guidelines

Food Storage & Safety

IMPORTANT : Vacuum packaging is NOT a substitute for refrigeration or freezing. Any perishable foods that require refrigeration must still be refrigerated or frozen after vacuum packaging.

For best result in extending the life of foods, it is important to vacuum package foods that are fresh. Once food has begun to deteriorate, vacuum packaging may only slow the deterioration process. Vacuum sealing cannot prevent the growth of mold. Other disease causing microorganisms can still grow in low oxygen environments and may require further measures to be eliminated.

Food Preparation Hints and Tips for Air-tight Vacuum Sealing

Cooking, Thawing and Reheating – Simmering in a vacuum bag helps food retain its flavor and it helps with the clean up as well. No dirty saucepans... When reheating foods in the microwave using your vacuum bags, always puncture open the bag to allow hot air to escape. You can also reheat foods in the vacuum bags by placing them in water at a low simmer below 170°F (75°C).

IMPORTANT : Always thaw foods in either refrigerator or microwave – do not thaw perishable foods at room temperature.

Preparation Hints for Meat and Fish :

Try pre-freezing meats and fish for 1-2 hours before vacuum packaging. This helps retain the juice and shape, and provides for a better seal.

If you can't, place a folded paper towel between the food and top of the bag, but below seal area. Leave paper towel in bag to absorb excess moisture and juices during vacuum packaging process.

Preparation Hints for Cheeses :

Vacuum package cheese after each use. If you make your bag just a little longer than needed, you can re-seal the bag after each use.

IMPORTANT : *Due to the risk of anaerobic bacteria, soft cheeses should never be vacuum packaged.*

Preparation Guidelines for Vegetables :

Blanching is a process that should be done before vacuum packaging vegetables. This process stops the enzyme action that could lead to loss of flavor, color and texture. To blanch vegetables, place them in Simmering water or in a microwave until they are cooked, but still crisp. Blanching times can range from 1 to 2 minutes for leafy greens and peas ; 3 to 4 minutes for snap peas, sliced zucchini or broccoli ; give your carrots about 5 minutes ; and 7 to 11 minutes for corn on the cob. After blanching, immerse vegetables in cold water to stop the cooking process.

NOTE : *All vegetables (including broccoli, Brussels sprouts, cabbage, cauliflower, kale, turnips) naturally emit gases, during storage. Therefore, after blanching, it's best if they're stored in the freezer.*

More on Vegetables :

Vegetables are a great candidate for portion control ; when storing vegetables, try pre-freezing them for 1 to 2 hours, then separate them into meal portions within your vacuum bags. After they have been vacuum packaged, return them to the freezer.

IMPORTANT : *Due to the risk of anaerobic bacteria, fresh mushrooms, onions & garlic should never be vacuum packaged.*

Preparation Hints for Powdery Foods :

When vacuum packaging powdery items like flour, it's best to use their original packaging inside of the vacuum bags. The fine powder could get sucked into the machine and cause enough damage to shorten the life of the sealer.

Preparation Hints for Liquids :

Before you vacuum package liquid such as soup stock, pre-freeze in a casserole dish, loaf pan or ice cube tray until solid. Remove frozen liquid from pan and vacuum package in the vacuum bags. You can then stack in the freezer. When you're ready to use, just cut corner of bag and place in either a microwave dish or drop into water at a low simmer, below 170°F (75°C).

Key Features of your New Vacuum Sealer

- Sleek design with low noise when working.
- Wide sealing line (up to 3mm) prevents air leakage and keeps high vacuum degree for a longer time.
- Easy lock system, slightly press the machine to lock.
- Press two buttons at bottom sides can unlock the cover easily.
- "Seal Only" function is available.
- Pre-seal the vacuum bag any time when vacuuming.
- Extra vacuum hole on the top of the machine for vacuuming canisters.
- Sealing width : MAX 30cm.

Main Parts of your New Vacuum Sealer

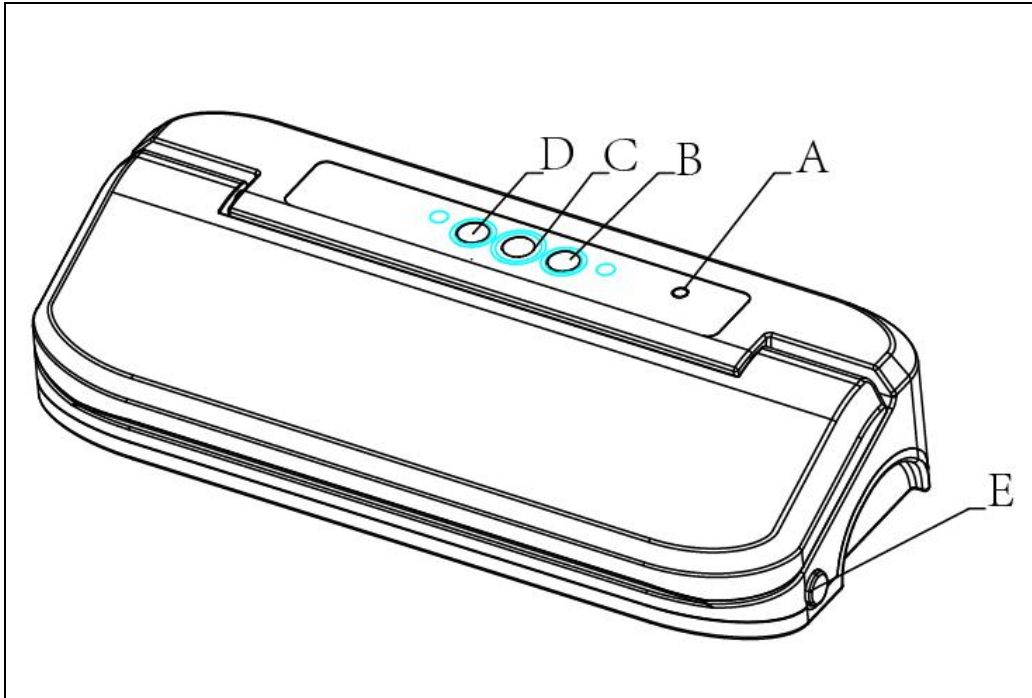

A. Port for Vacuuming Canister

Insert one end of accessory hose into port on appliance, put the other end onto canister port, then let the appliance make the canister vacuum fresh.

B. Vacuum & Seal Button

Press to vacuum package and seal food airtight. Appliance shuts off automatically.

C. Cancel Button

Immediately halts the current function.

D. Seal Only Button

This button has three uses:

1. Press to create a seal when making bags from a roll.
2. Press to immediately stop the vacuum process and begin sealing the bag. Preventing delicate foods from being crushed.
3. Press to create a seal on Mylar bags (such as a potato chip bag) to keep food sealed airtight.

E. Release Button

Press to open lid after sealing process is completed.

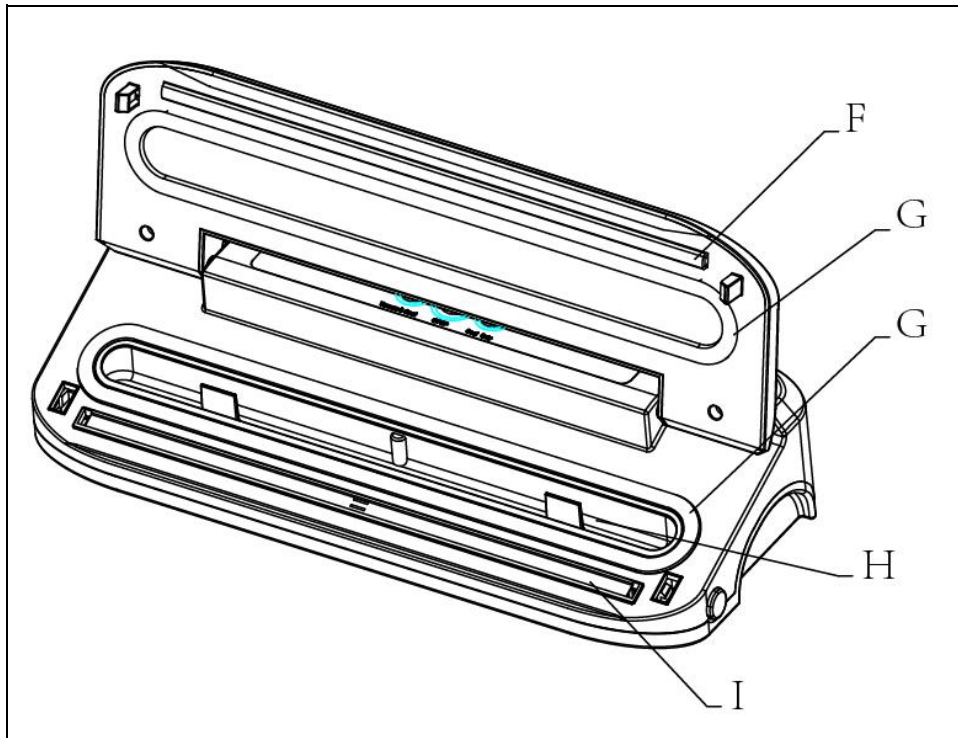

- F. Rubber Sealing Strip**
- G. Sealing Gaskets (up and down)**
- H. Vacuum Chamber**
- I. Sealing Wire / Heater**

How to Make Custom Sized bags

1. Pull enough bag material to hold item to be vacuum packaged, plus 2 inches. With a pair of scissors or sharp knife, cut desired bag length from bag roll. Make sure to cut in a straight line. Plug in power cord.
2. Open lid. Place one end of cut bag onto sealing strip, don't worry if you accidentally place any material onto the gasket area.



-
3. Close lid firmly by pressing down firmly on both sides, check to make sure that the lid will not open. If the lid can not be lifted, then you have successfully locked the lid in place.

NOTE: The sealing strip will NOT work properly unless you lock the lid. Ensure that the lid has been locked on both sides for proper sealing.

4. Now that the lid has been locked, press the **"Seal Only"** button to create a custom sized bag. The indicator light illuminates during the seal process.
5. Once completed the indicator light will turn off; press the release buttons on both sides of the machine, it is now safe to take out the newly created bag.
6. The custom sized bag is now ready for vacuum sealing.

CAUTION: Make sure you give the appliance time to cool down. Wait at least 20 seconds between seals. Under very heavy usage, appliance will shut off automatically to prevent overheating. If it does, wait 20 minutes to allow appliance to cool off.

How to Vacuum Seal with the Vacuum Bags

1. Place the item(s) to be sealed into the pre-cut or custom sized bag. Leave at least 2 inches between the contents and the top of the bag to allow for bag contraction.
2. Open lid and place the open end of the bag down into the Vacuum channel.



3. Close lid firmly by pressing down firmly on both sides, check to make sure that the lid will not open. If the lid can not be lifted, then you have successfully locked the lid in place.
4. To begin the vacuum process, press the **"Vacuum & Seal"** button. The unit will continue to vacuum and then seal once air has been removed.

-
5. Once the indicator light has turned off, press the release buttons on both sides of the machine to release the bag.

How to Use the Vacuum Sealer with a Canister

NOTE : Canister is not included, accessory hose may not fit all canister lids.

1. Wipe canister cover, canister base and ensure they are clean and dry.
2. Place food into canister and leave at least one inch of space between food and cover.
3. Place cover onto canister, insert one end of accessory hose into port on appliance. Put the other end onto canister port ; pressing down firmly to ensure a tight fit.
4. Close lid by pressing down on both sides. If the lid cannot be lifted, then you have successfully locked the lid in place.
5. To begin the vacuum process, press the "Vacuum & Seal" button. The unit will continue to vacuum and then seal once air has been removed.
6. Once the indicator light has turned off, it is safe to remove accessory hose from machine and canister.

Care & Cleaning

1. Always unplug the unit before cleaning.
2. Do not immerse in water.
3. Do not use abrasives to clean the unit.
4. Wipe the outer surface with a soft, damp cloth and soap.
5. To clean the inside of the unit, wipe away any food or liquid with a paper towel.
6. Dry all parts thoroughly before you plug in and operate the unit again.
7. Vacuum chamber may trap liquids that were drawn from the bag ; use a mild dish washing soap and a warm, damp cloth to wipe away any left behind liquid from the vacuum chamber. Dry thoroughly.

Trouble Shooting

Nothing happens when I press the "Vacuum & Seal" button:

- Make sure the power cord is correctly plugged into the electrical outlet.
- Make sure the power cord is not damaged in any way.
- Make sure the electrical outlet is operative by plugging in another appliance. If it's not, please check the circuit breakers or fuses in your home.

-
- Make sure the bag is positioned correctly down in the vacuum chamber.
 - Press down on both sides of the lid and make sure it is locked in place.
 - Wait 25 minutes to allow appliance to cool off, and then try using again.

Air is not vacuumed from the bag:

- Check that there are no gaps, folds, wrinkles or holes in the pre-sealed bags.
- Check for loose, worn or cracked Upper and Lower sealing gaskets.
- Foods with high liquid contents may prevent the bag from sealing properly. Cut bag open and wipe top inside of bag and reseal.
- Check to see if bag is properly inserted into the vacuum chamber.
- Make sure you've placed the bag in the proper place. When making a bag from a roll, make sure end of cut piece is on the sealing strip.

Bag melts:

- The sealing strip may have been too hot during the sealing process. Allow the unit to cool for 20 seconds between uses. If the bag continues to melt, allow unit to cool with the lid in the upright position for 25 minutes before using.

Air has seeped back into the vacuumed bag:

- Check the seal of the bag. There may be a hole or wrinkle that is allowing air to reenter the bag. Carefully cut the bag open and re-seal it, or use an entirely new bag.
- Make sure there is no moisture or liquid from the food present within the bag seal. You may need to cut open the bag and re-seal it, or use an entirely new bag. Partially freeze foods with excess liquids, prior to vacuum sealing.
- Make sure there are no food items with sharp edges that may have punctured the bag. If you find a puncture hole, seal the item in an entirely new bag.
- Make sure no liquids were drawn to the sealing strip area.
- Check for loose, worn or cracked Upper and Lower sealing gaskets.
- Moisture of foods with high liquid content will prevent the bag from sealing properly. Cut bag open and wipe top inside of bag and reseal.

Bag will not seal:

- Check that there aren't any gaps, folds, wrinkles or holes in pre-sealed edges.
- Moisture of foods with high liquid content will prevent the bag from sealing properly. Cut bag open and wipe top inside of bag and reseal.
- Make sure you've placed the bag in the proper place. When making a bag from a roll, make sure end of cut piece is on the sealing strip.
- Make sure you've given the appliance time to cool down. Wait 20 seconds between seals.

Service Instructions

1. Do NOT attempt to repair or adjust any electrical or mechanical functions on this unit. Doing so will void the warranty.
2. If you have any questions or comments regarding the unit's operation or believe any repair is necessary, please contact our after-sales department.