

USER'S MANUAL

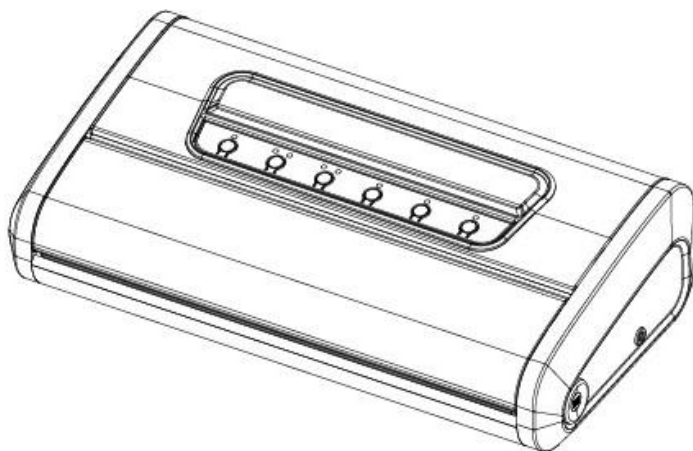

Vacuum Sealer VS200

220-240V~50Hz

165W

Important Points for your Safety

Read and fully understand all instructions and warnings prior to using this machine. Your safety is most important !

1. Read the instructions carefully.
2. Do not allow the appliance to be used as a toy.
3. This appliance should not be operated by children.
4. Do not operate the appliance with a damaged power cord or plug.
5. Do not use the appliance on a wet or hot surface, or near a heat source.
6. Always use the appliance on a level surface.
7. Do not immerse any part of the appliance, power cord or plug into water or other liquid.
8. To disconnect, unplug the power cord from the electrical outlet. Do not disconnect by pulling on the cord. Always unplug the appliance before cleaning and when not in use.
9. Do not operate the appliance if it malfunctions or is any way damaged. If the cord or the machine is damaged, please return it to our after-sales department for proper service, replacement or repair.
10. Close supervision is required when this product is used near children.
11. The appliance is not for commercial use. If sealing more than 20 bags continuously, wait at least 25 minutes before resuming use of your appliance.
12. Keep the upper lid of the appliance unlocked when not in use.

This appliance is for HOUSEHOLD USE ONLY.

Do not attempt to service this product. Service should be performed by an authorized service representative.

A short power-supply cord is provided to reduce the risk resulting from becoming entangled in or tripping over a longer cord. Extension cords are not prohibited from being used when care is exercised in their use. When an extension cord is used the marked electrical rating of the extension cord shall be no less than the marked electrical rating of the appliance. The longer cord shall be arranged so that it does not drape over the counter-top or tabletop where it is capable of being tripped over, snagged, or pulled on unintentionally, especially by children.

Start Enjoying the Benefits of your Vacuum Sealer System

Thank you for purchasing this vacuum sealer.

Your new vacuum sealer system includes the following :

- VS200(S) Vacuum Sealer
- User Manual
- Starter Bags

Vacuum Sealing Guidelines**Food Storage & Safety**

IMPORTANT : Vacuum packaging is NOT a substitute for refrigeration or freezing. Any perishable foods that require refrigeration must still be refrigerated or frozen after vacuum packaging.

For best result in extending the life of foods, it is important to vacuum package foods that are fresh. Once food has begun to deteriorate,

vacuum packaging may only slow the deterioration process. Vacuum sealing cannot prevent the growth of mold. Other disease causing microorganisms can still grow in low oxygen environments and may require further measures to be eliminated.

Food Preparation Hints and Tips for Air-tight Vacuum Sealing

Cooking, Thawing and Reheating – Simmering in a vacuum bag helps food retain its flavor and it helps with the clean up as well. No dirty saucepans... When reheating foods in the microwave using your vacuum bags, always puncture open the bag to allow hot air to escape. You can also reheat foods in the vacuum bags by placing them in water at a low simmer below 170°F (75°C).

IMPORTANT : Always thaw foods in either refrigerator or microwave – do not thaw perishable foods at room temperature.

Preparation Hints for Meat and Fish :

Try pre-freezing meats and fish for 1-2 hours before vacuum packaging. This helps retain the juice and shape, and provides for a better seal.

If you can't, place a folded paper towel between the food and top of the bag, but below seal area. Leave paper towel in bag to absorb excess moisture and juices during vacuum packaging process.

Preparation Hints for Cheeses :

Vacuum package cheese after each use. If you make your bag just a little longer than needed, you can re-seal the bag after each use.

IMPORTANT : Due to the risk of anaerobic bacteria, soft cheeses should never be vacuum packaged.

Preparation Guidelines for Vegetables :

Blanching is a process that should be done before vacuum packaging vegetables. This process stops the enzyme action that could lead to loss of flavor, color and texture. To blanch vegetables, place them in Simmering water or in a microwave until they are cooked, but still crisp. Blanching times can range from 1 to 2 minutes for leafy greens and peas ; 3 to 4 minutes for snap peas, sliced zucchini or broccoli ; give your carrots about 5 minutes ; and 7 to 11 minutes for corn on the cob. After blanching, immerse vegetables in cold water to stop the cooking process.

NOTE : All vegetables (including broccoli, Brussels sprouts, cabbage, cauliflower, kale, turnips) naturally emit gases, during storage. Therefore, after blanching, it's best if they're stored in the freezer.

More on Vegetables :

Vegetables are a great candidate for portion control ; when storing vegetables, try pre-freezing them for 1 to 2 hours, then separate them into meal portions within your vacuum bags. After they have been vacuum packaged, return them to the freezer.

IMPORTANT : Due to the risk of anaerobic bacteria, fresh mushrooms, onions & garlic should never be vacuum packaged.

Preparation Hints for Powdery Foods :

When vacuum packaging powdery items like flour, it's best to use their original packaging inside of the vacuum bags. The fine powder could get sucked into the machine and cause enough damage to shorten the life of the sealer.

Preparation Hints for Liquids :

Before you vacuum package liquid such as soup stock, pre-freeze in a

<http://www.ysvacuumsealer.com> 5

casserole dish, loaf pan or ice cube tray until solid. Remove frozen liquid from pan and vacuum package in the vacuum bags. You can then stack in the freezer. When you're ready to use, just cut corner of bag and place in either a microwave dish or drop into water at a low simmer, below 170°F (75°C).

Key Features of your New Vacuum Sealer

- Machine size: 390*200*100mm
- "Pulse" button to control vacuum time and degree.
- Optional motor speed (high / low).
- Separate vacuum mode for dry and moist food.
- With roll compartment and integrated safety cutting facility.
- Double sealing, each wide sealing line up to 3mm, prevents air leakage.
- Seal only function.
- Sealing length: MAX 32cm
- Vacuum pressure: -0.70~-0.90bar

Main Parts of your New Vacuum Sealer

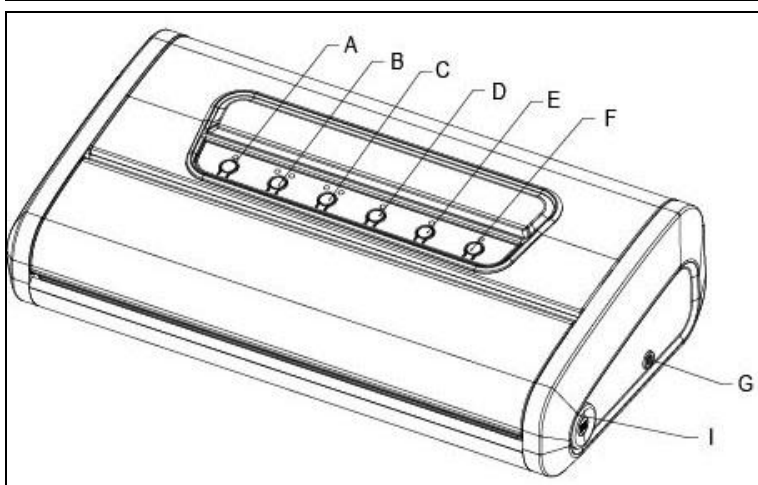

A VACUUM&SEAL CANCEL

Press this button to start vacuumizing, when the process is done, the machine will seal the bag automatically. If you press this button while the machine is working, it means to stop the on-going process.

B SPEED (LOW/HIGH)

Press this button to choose the machine vacuumize in low or high speed.

C Food (DRY/MOIST)

Press this button to choose vacuumizing pattern for dry food OR moist food.

D CANISTER

Press this button to make vacuum with canister.

E PULSE VAC

This button is used when extreme control of the vacuuming process is needed for delicate foods. Press the button and the vacuum pumps turns on, release the button and it shuts off.

F SEAL ONLY

Press to create a seal when making bags from bag roll.

Press to immediately stop the vacuum process and begin sealing the bag.

G ACCESSORY PORT

Allows vacuum packaging with Canisters and Accessories.

I LOCKS

Press left and right side locks to close or open the cover.

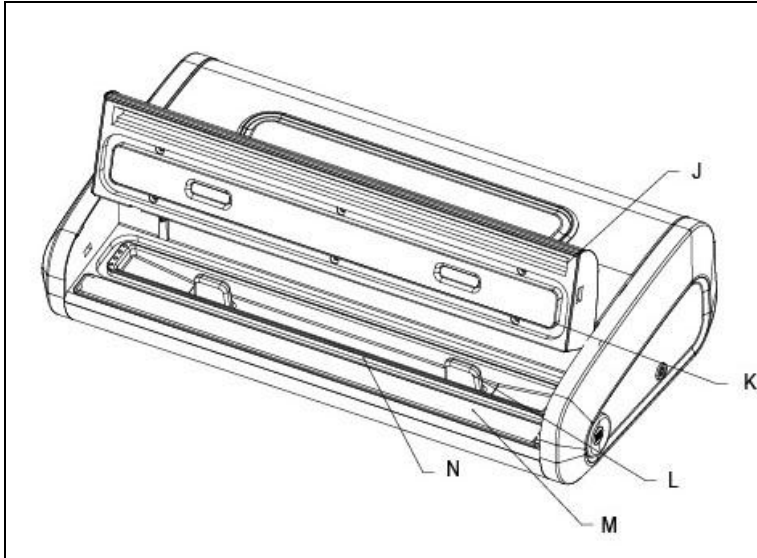

J HEATING BAR COVERED BY MEGA TAPE

K SEALING FOAM RING

L REMOVABLE TRAY

This part can be taken away when cleaning .

M SILICON SILING LINE

N VACUUM CHAMBER

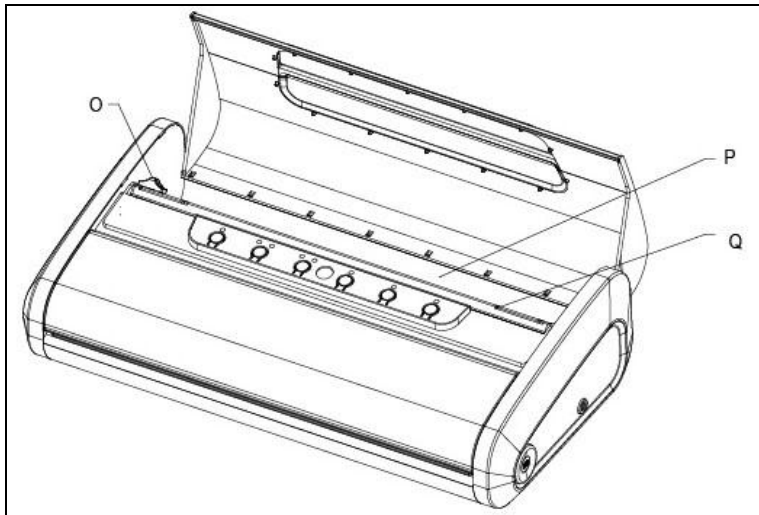

O&Q EMBEDDED CUTTER

Use this cutter to cut bag materials from rolls.

P ROLL STORAGE

Place roll inside this area.

How to Make Custom Sized Bags

1. Put a bag roll into the roll storage area, pull enough bag material to hold item to be vacuum packaged, plus 2 inches. Use the embedded cutter on the sealer to cut desired bag length from bag roll. Make sure to cut in a straight line. Plug in power cord.
2. Open lid. Place one end of cut bag onto sealing strip, don't worry if you accidentally place any material onto the gasket area.
3. Close lid by pressing down on both sides until two "click" sound heard.
4. Now that lid has been locked, press the "SEAL" button to create a custom sized bag. The indicator light illuminates during the seal

process.

REMARK : When the sealer is used for the first time, the double sealing line may not be well done, this is because the heating bar needs time to reheat, in this case, just try another time.

5. Once completed the indicator light of seal button will turn off; press the release buttons on both sides of the machine, it is now safe to take out the newly created bag.
6. The custom sized bag is now ready for vacuum sealing.

CAUTION : Make sure you give the appliance time to cool down. Wait at least 20 seconds between seals. Under very heavy usage, appliance will shut off automatically to prevent overheating. If it does, wait 25 minutes to allow appliance to cool off.

How to Vacuum Seal with the Vacuum Bags

1. Place the item(s) to be sealed into the pre-cut or custom sized bag. Leave at least 2 inches between the contents and the top of the bag to allow for bag contraction.
2. Open lid and place the open end of the bag down into the vacuum chamber.

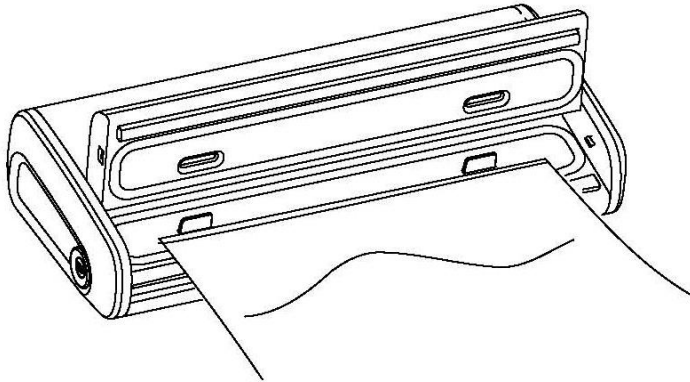

3. Close lid by pressing down on both sides until two "click" sound heard.
4. Choose low or high speed, dry or moist food.
NOTE : When vacuumizing moist food, please choose low speed and moist food pattern.
5. To begin the vacuum process, press the "VACUUM&SEAL" button. The unit will continue to vacuum and then seal once air has been removed.
6. Once the indicator light has turned off, press the release buttons on both sides of the machine to release the bag.

How to Use the Pulse Vacuum Button (PULSE VAC)

Since the pressure under the normal vacuum function is set to be high, sometimes it is easy to destroy some delicate items by high pressure in the vacuum bags. In this case, you can use the "PULSE" vacuum function to control the vacuum time and pressure, and prevent crushing delicate items. When packing some juicy foods, you can also use this

<http://www.ysvacuumsealer.com> 11

function and prevent liquid being sucked out.

1. Place the item(s) to be sealed into the pre-cut or custom sized bag. Leave at least 2 inches between the contents and the top of the bag to allow for bag contraction.
2. Open lid and place the open end of the bag down into the vacuum chamber.
3. Close lid by pressing down on both sides.
4. Press the "PULSE" button continually, till it reaches the pressure that you want. You can watch the vacuum bag to decide the pressure. During this process, you can stop vacuum by stop pressing this button ; and press it again to vacuum again.
5. When the pressure reaches what it needs, press "SEAL ONLY" button to start sealing.
6. Once the indicator light has turned off, press the release buttons on both sides of the machine to release the bag.

Care & Cleaning

1. Always unplug the unit before cleaning.
2. Do not immerse in water.
3. Do not use abrasives to clean the unit.
4. Wipe the outer surface with a soft, damp cloth and soap.
5. To clean the inside of the unit, wipe away any food or liquid with a paper towel.
6. Dry all parts thoroughly before you plug in and operate the unit again.
7. Vacuum chamber may trap liquids that were drawn from the bag ; it can be removed from the sealer, use a mild dish washing soap and a warm, damp cloth to wipe away any left behind liquid from the

vacuum chamber. Dry thoroughly.

8. Keep the upper lid of the appliance unlocked when not in use.

Trouble Shooting

Nothing happens when I press the "VACUUM" button:

- Make sure the power cord is correctly plugged into the electrical outlet.
- Make sure the power cord is not damaged in any way.
- Make sure the electrical outlet is operative by plugging in another appliance. If it's not, please check the circuit breakers or fuses in your home.
- Make sure you have turned on the power switch on the back of the machine.
- Make sure the bag is positioned correctly down in the vacuum chamber.
- Press down on both sides of the lid and make sure it is locked in place.
- Wait 25 minutes to allow appliance to cool off, and then try using again.

Air is not vacuumed from the bag:

- Check that there are no gaps, folds, wrinkles or holes in the pre-sealed bags.
- Check for loose, worn or cracked Upper and Lower sealing gaskets.
- Foods with high liquid contents may prevent the bag from sealing

properly. Cut bag open and wipe top inside of bag and reseal.

- Check to see if bag is properly inserted into the vacuum chamber.
- Make sure you've placed the bag in the proper place. When making a bag from a roll, make sure end of cut piece is on the sealing strip.

Bag melts:

- The sealing strip may have been too hot during the sealing process. Allow the unit to cool for 20 seconds between uses. If the bag continues to melt, allow unit to cool with the lid in the upright position for 25 minutes before using.

Air has seeped back into the vacuumed bag:

- Check the seal of the bag. There may be a hole or wrinkle that is allowing air to reenter the bag. Carefully cut the bag open and re-seal it, or use an entirely new bag.
- Make sure there is no moisture or liquid from the food present within the bag seal. You may need to cut open the bag and re-seal it, or use an entirely new bag. Partially freeze foods with excess liquids, prior to vacuum sealing.
- Make sure there are no food items with sharp edges that may have punctured the bag. If you find a puncture hole, seal the item in an entirely new bag.
- Make sure no liquids were drawn to the sealing strip area.
- Check for loose, worn or cracked Upper and Lower sealing gaskets.
- Moisture of foods with high liquid content will prevent the bag from sealing properly. Cut bag open and wipe top inside of bag and

reseal.

Bag will not seal:

- Check that there aren't any gaps, folds, wrinkles or holes in pre-sealed edges.
- Moisture of foods with high liquid content will prevent the bag from sealing properly. Cut bag open and wipe top inside of bag and reseal.
- Make sure you've placed the bag in the proper place. When making a bag from a roll, make sure end of cut piece is on the sealing strip.
- Make sure you've given the appliance time to cool down. Wait 20 seconds between seals.

Service Instructions

1. Do NOT attempt to repair or adjust any electrical or mechanical functions on this unit. Doing so will void the warranty.
2. If you have any questions or comments regarding the unit's operation or believe any repair is necessary, please contact our after-sales department.